

Operating manual

Mega - Marker

Schilling Marking Systems GmbH
In Grubenaecker 1
D-78532 Tuttlingen

Tel.: 07461 – 9472 – 0
Fax: 07461- 9472 – 28

<http://www.marking-systems.de>
<http://www.mega-marker.de>

e-mail: info@Marking-Systems.de

Mega - Marker



Dear Customer,

With your purchase of the *Mega-Marker*, you have opted for one of the best marking systems on the market.

This operating manual aims to help you to proceed with user-friendly inputs at the hand-held device in next-to-no time to produce outstanding, professional marking results on your product. Starting with the standard parameters, you will soon find the ideal setting for your own parameters so that you can use the marker to produce excellent lettering and make full use of all the possibilities of this product.

The marker featured in this manual complies with valid safety regulations. As long as it is operated according to this manual, the *Mega-Marker* poses absolutely no risk to operator or workpiece.

Technical modifications on the basis of new research and technology will be introduced without prior announcement.

You can download software updates conveniently under www.Mega-Marker.de.

We now wish you lots of fun and every success in using the *Mega-Marker*.

Your SCHILLING team

The content and documentation is owned by Schilling Marking Systems GmbH. It must not be distributed or duplicated as photocopy, sound recording, video, print or microfilm in any form without the approval of the management. This applies in particular to distribution of the data in electronic form or on a data carrier.

The company reserves all rights to compensation for damage to the company caused by a failure to comply.



Contents

Important safety instructions	5
Scope of delivery and installation of the Mega-Marker	6
Scope of supply of the standard device	6
Installation of the Mega-Marker	7
Power supply	7
Pneumatic supply	7
Needle component	7
Spacing of needle to workpiece	7
Connecting the hand-held	7
Scope of supply of the hand-held	9
Optional accessories	10
Introduction to marking technology	11
Penetration depth	11
Needle frequency	12
Speeds	12
Pulses	12
Waiting time start	13
Waiting time stop	13
Needle	13
Job management	15
Adjusting your first settings	16
Adjusting the time	16
Adjusting the date	16
User number	16
Creating a job	18
Creating a text block	19
Creating the text and character parameters	20
Text height and character width	20
Character spacing	20
Text slant	21
TEACH IN	21
Text anchor	22
Text anchor – at an angle	23
Text anchor – in the round	24
Text anchor – in the round	25
Text anchor – in the round	26
Creating a date block	27

Creating a counter	28
Creating a graphic element	30
Line	30
Square	30
Rectangle	31
Circle	31
Oval	32
Creating the marking parameters	33
Needle	33
Reference run	34
Marking speed	34
Working range	35
Moving the group	36
Approaching positions	37
Reference run	39
Transferring the job to the marker	40

Important safety instructions

Read the instructions for installation of the device, this can prevent possible damage to the device.

1. The device must only be operated with the supplied cables and leads.
2. Do not place anything on the cables and connections.
3. Position the device and connections in such a way that no one can step on them, drive over them or stumble over them.
4. The device requires no maintenance. The device can be damaged if the covers are opened or removed.
5. Damage to the security seal makes all guarantee and warranty claims null and void.
6. Study the operating manual thoroughly before changing any parameters and settings.
7. Use dry, dust-free and oil-free compressed air. Otherwise damage can be caused to the solenoid valves, producing incorrect marking results.

Contact our technical maintenance staff if

- the mains cable is worn through or the mains connector/adaptor is damaged;
- the transfer cable is worn through or the connector is damaged;
- liquid has been split on the device;
- the device has been exposed to rain or water;
- the device has been dropped or damaged;
- the output of the device or the marking quality changes clearly.

Incorrect connections or settings can cause damage which then has to be corrected in a difficult, complicated procedure by a qualified technician to make sure that the device works properly again.

Information on the operating manual:

General statements are made in black print.

Red print refers to safety instructions or important information.

Blue print gives you instructions to be carried out.

Please let us know if certain passages are confusing or even incomprehensible. We are always glad to receive your suggestions.

Scope of supply and installation of the *Mega-Marker*

The scope of supply of the standard device includes

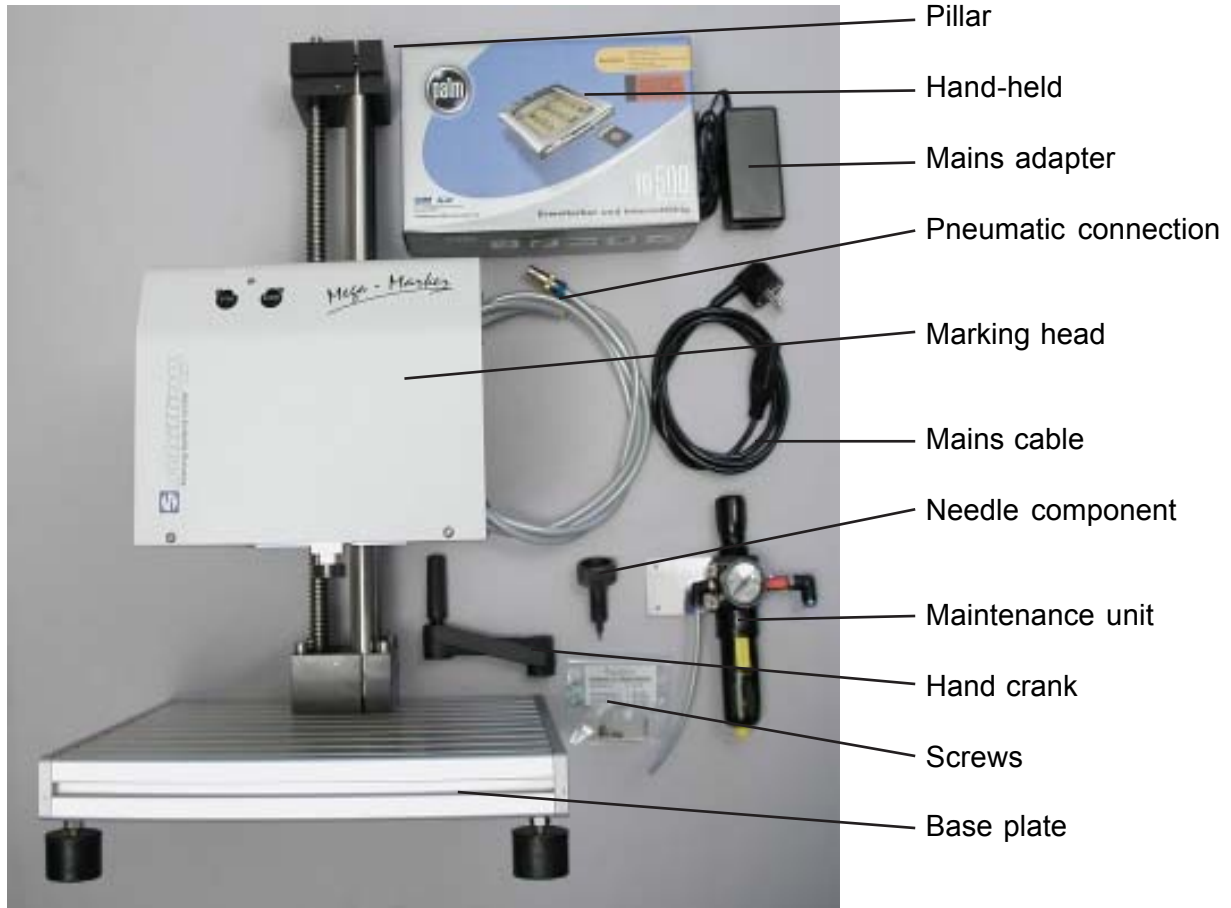

The back of the *Mega-Marker*

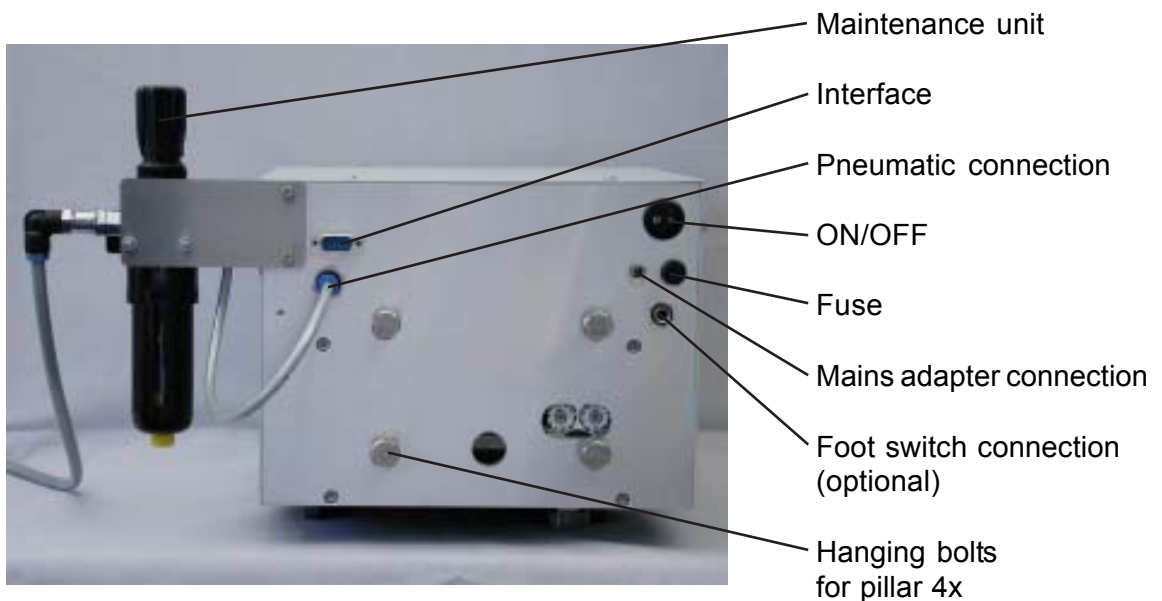

Installation of the Mega-Marker

Mount the crank handle to the pillar and the maintenance unit to the back right of the marking head.

Power supply

Please ensure that the mains switch is set to OFF (O).
Connect the mains adapter to the marking head (connection back left of the marking head).
Connect the mains cable to the mains adapter. Connect the mains cable to a suitably fused socket.

Pneumatic supply

Connect the short pneumatic hose with the inlet on the back right of the marking head and with the outlet on the maintenance unit (left). Then connect the pneumatic supply hose in the inlet of the maintenance unit, and then in the pneumatic supply network. Proceed in the correct order!

Caution! Use dry, dust-free and oil-free compressed air. Otherwise the solenoid valves can be damaged.

Needle component

Loosen the fixing screw on the right of the pillar and crank the marking head upwards so that you can fit the needle component easily.

Check the needle component!

It consists of the needle holder housing, a plain washer 6 mm inner diameter, spring and needle with piston.

Proceed with assembly as follows:

First place the washer in the cylinder, then the spring on the washer, and then insert the needle!

When fitting the device, do not tighten the needle holder too tight because otherwise the O-ring can get crushed.

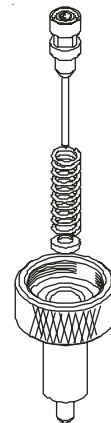

Now open the shut-off valve at the maintenance unit and adjust the pressure initially to approx. 2.5 bar. If the marking is too fine, increase the pressure as required.

Spacing needle to workpiece

After mounting a workpiece adapter or similar and inserting a workpiece, turn the marking head down until the needle tip is approx. 1 to 1.5 mm from the workpiece. Fix the marking head in this position with the fixing screw.

Connecting the hand-held

Connect the data transfer cable to the 9-pin jack on the back right of the marker (above the pneumatic inlet) and screw tight.

Mega-Marker
ready mounted

Mega-Marker
ready mounted

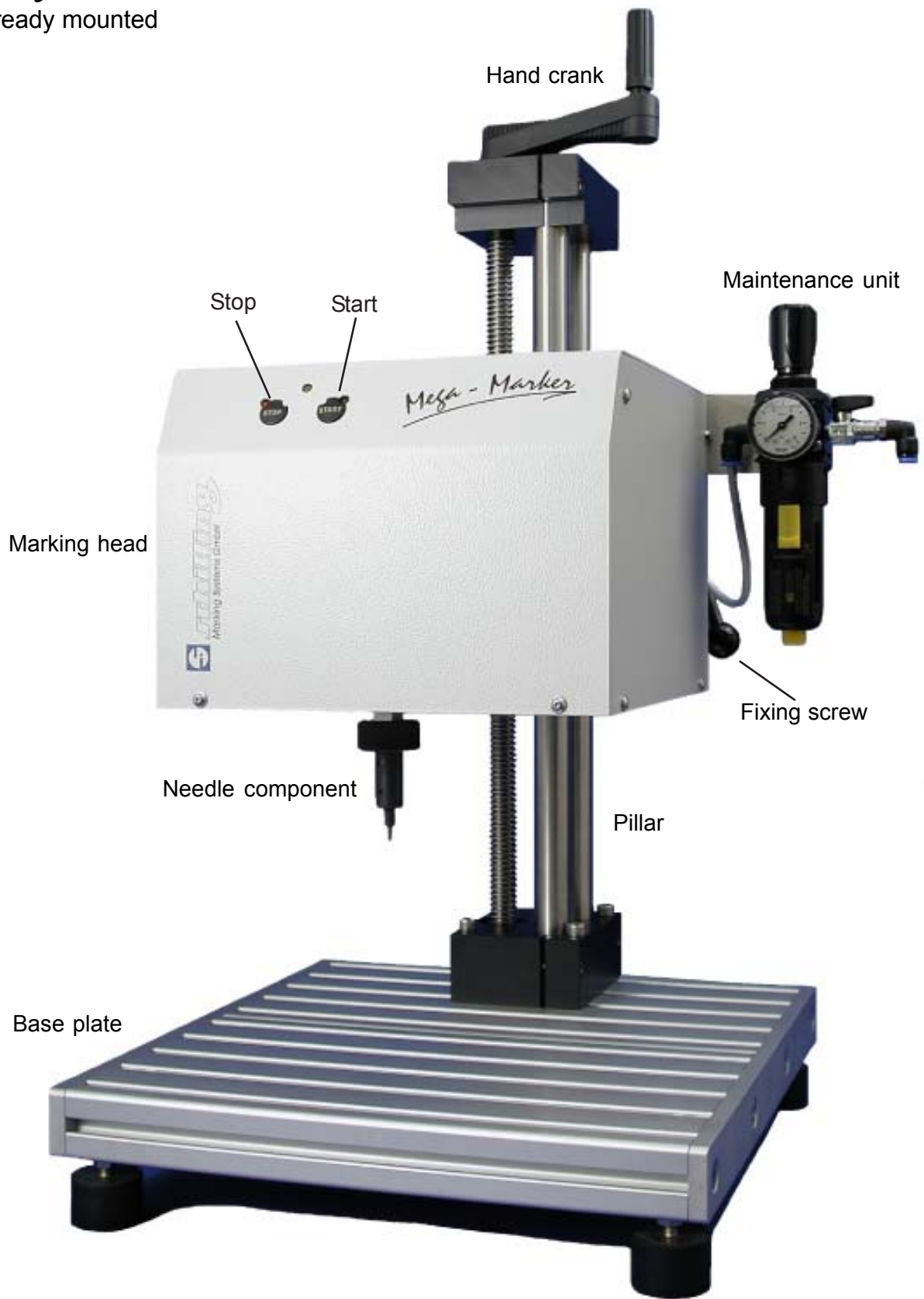

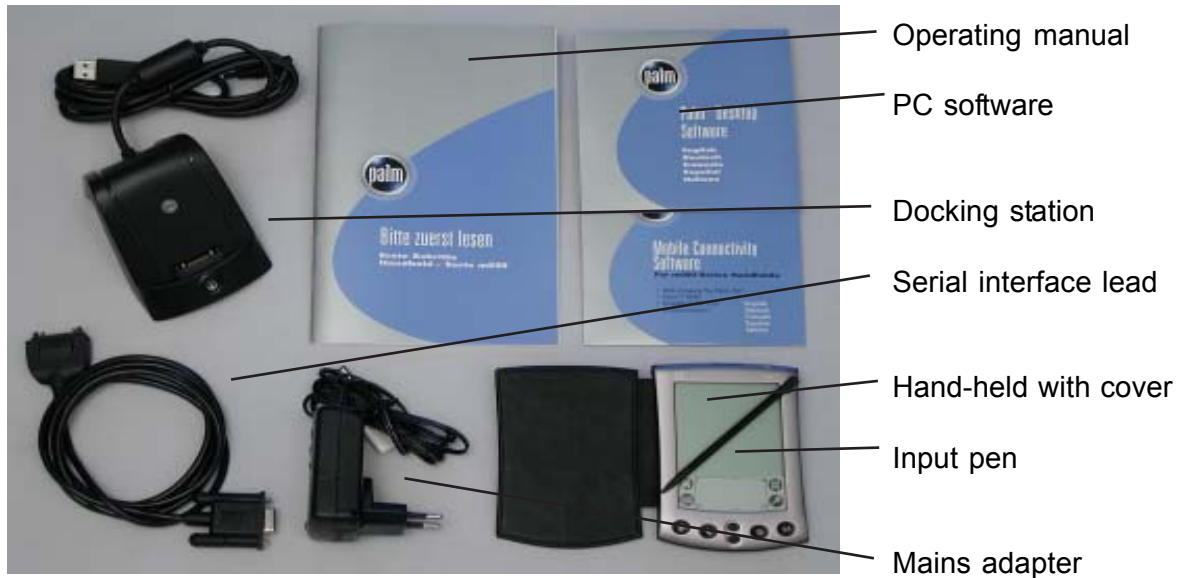

At this particular point we can only draw your attention to the extensive functions of the hand-held, without going into any further detail.
We only use the possibilities relevant to our own purposes.

Please read the manufacturer's operating manual.

Switching on/off: briefly press the transparent button with the green dot.



The upper two-thirds of the hand-held window are for inputs with the input pen which you will find top right on the side of the hand-held.
The lower third has five boxes for general palm use.

One of the most frequently used boxes is the small „abc“. Touch this box to access the keyboard so that you can enter figures and numbers, like on your computer keyboard.

The six buttons in the lower part of the hand-held have no prime functions for the *Mega-Marker*.

Optional accessories:

Foot switch

The foot switch is connected to the back of the *Mega-Marker* and makes it easier to start the marking process if the workpiece is being held under the marking needle with both hands.

Needles

3 mm needle, light with soft spring

3 mm needle, medium heavy with hard spring

6 mm needle, heavy-duty version with hard spring, heavy needle holder.

All needles available in 60°, 90° and 118° angles.

Special needle and needle holder lengths available on request.

Workpiece adapters

On request we can also gladly supply workpiece adapters produced especially to your needs, or can help you to procure fixing aids. It goes without saying that we will gladly provide advice and support here.

Company logos

Are produced by us and installed on your *Mega-Marker* on request.

Special characters

The most common special characters are stored in the keyboard of your hand-held. On request we can also produce special characters to your specifications.

PC software

Your Mega-Marker can also be operated by computer. The computer screen then shows the palm which you can operate from the keyboard and with the mouse.

Introduction to marking technology

The marking procedure **displaces material**, and does not remove it. This means the material is compacted at the point where the needle penetrates the material surface. At the same time the material is displaced, producing a warp of material at the side and before the needle puncture point.

The deeper the needle penetrates the material, the higher the material warp.

Penetration depth

Is defined by the needle weight, the spacing of the needle to the workpiece and the pressure applied to the needle, together with the geometry of the needle tip.

Regardless of needle type and geometry, as a basic rule it always applies that:

the larger the spacing of the needle to the workpiece, the higher the pressure setting at the maintenance unit, the deeper the marking.

The **penetration depth** defines the marking quality!

Fine lettering : slight depth

Keep the needle spacing to the workpiece as small as possible (approx. 0.5 mm)

Reduce the pressure at the pressure valve accordingly (approx. 1.5 – 1.8 bar)

Uses:

- for very thin material
- for very small lettering (e.g. 0.5 mm lettering height)
- to avoid material warping at the displacement point

Normal lettering – medium depth – light needle component

Needle spacing approx. 1 mm to 1.5 mm above the material surface.

Pressure approx. 2.5 bar (depends on the material)

Uses:

- for the most common marking types with character height > 1 mm

Strong lettering – very low depth – heavy needle component

Needle spacing larger than 2 mm, increase pressure accordingly (between 4 and 7 bar).

Not suitable for lettering heights less than 10 mm.

Uses:

- for surfaces which may be sanded over,
- for surfaces which may be painted,
- for particularly rough material (grey cast iron, sawn surfaces, etc.)

Needle frequency and speed also affect the marking quality.

Needle frequency

Needle frequency in Hertz (Hz) indicates how often the needle is extended per second.

Examples:

10 Hz, the needle is extended 10 times per second (very slow)

50 Hz, the needle is extended 50 times per second (medium)

100 Hz, the needle is extended 100 times per second (fast)

The lower the Hertz number, the fewer dots are marked! If you also increase the marking speed, even fewer dots are marked. This produces „stress-free“ marking for the material. Vice versa, the higher the Hertz number, the more dots are marked. Reducing speed results in even more dots, producing very good marking.

Standard lettering with the *Mega-Marker* is produced with 80 Hz.

Speeds

The speeds are stated in millimetres per second (mm/s).

The **marking speed** is the time in which the needle moves during the marking procedure.

10 mm/s are sufficient for standard lettering.

The **fast speed** is the distance between the zero point to the start of the lettering, between the individual vectors within a character and between the characters. The fast speed should be identical with the marking speed, but can be increased. The maximum fast speed should not exceed 60 mm/s.

The **reference run** describes moving the needle to the reference position and should not exceed a speed of 40 mm/s.

Pulses

The pulses are the times in which the valve opens and closes. These times are stated in milliseconds (ms).

The **first pulse** gives the needle enough air to penetrate the workpiece deep enough at the first point, starting from its rest point. If the time setting is too high, the first puncture is clearly visible. In standard lettering, the time of the first pulse should be clearly less than the following pulses or be suppressed completely (1 ms).

For the **following pulses**, the needle is already moving so it does not need so much air as for the first time. For standard lettering the time should be 2.9 ms.

Waiting time start

Here you can adjust whether the needle should move straight away or wait briefly. The standard setting is 1 ms. This function is only important for very special marking tasks, e.g. for the 2D matrix code.

Waiting time stop

Similarly to the waiting time start, here the needle waits after the moved vector. The setting for standard lettering is 1 ms.

Needle

The standard scope of supply includes a soft spring with a light needle with a 118° tip. Many tests have revealed that this generally produces the best results. However, it is not possible to generalise here because the marking results depend on the material of the workpiece being marked, and on the character size. The needles are made of carbide and can be reground using a diamond wheel if necessary.

Our needles are available with a tip geometry of 60°, 90° and 118° - depending on application. We can produce other tips on request.

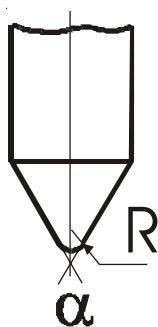

Needle	Needle	Geometry	Radius
3 mm	6 mm	60°	R = 0,3 mm
3 mm	6 mm	90°	R = 0,5 mm
3 mm	6 mm	118°	R = 0,5 mm

Mega-Fly

Input and processing program for the *Mega-Marker*.



Pull the input pen out of the hand-held. It is used to operate the palm.

After switching on, the basic menu appears.

Top line: time, battery status and setting possibilities for the basic menu.

Ensure that the battery is always charged!



Touch the icon to open the program for controlling the *Mega-Marker*

When the program is active:



Touch to open the numbers and special characters keyboard



Touch to open the keyboard



If the device switches off after no inputs have been made for 2 minutes, no information is lost. The time for the „power saving mode“ can be adjusted. See operating manual for the hand-held!

Job management

Mega-Fly starts with „job management“.



„Job management“ manages all programmed lettering and marking layouts (jobs) and transfers them to the marker.

A job can consist of at least one character, one word, several lines, text blocks, date blocks or counting blocks.

The icons new, rename and delete have the following meaning:

 A new job is created.

 The job can be renamed.

 The job is deleted.

The same functions or two other functions are available by

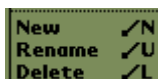

Job Manager touching – this opens the sub-menu

 have the same functions as the icons

 an **existing** job can be edited

 Search function in case several jobs are being managed

Palm Mega Job Fly This bar offers functions for rapid access to changing certain parameters of existing jobs:

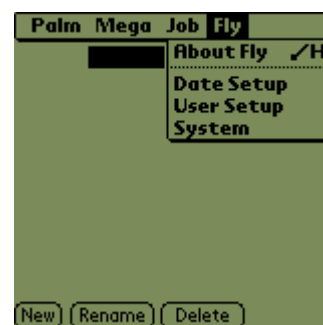
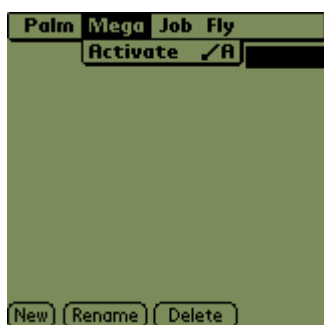

The individual functions will be described in detail later on.

Job management

Adjusting your first settings:

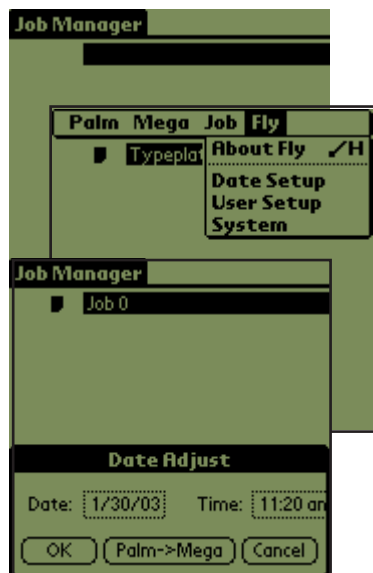

Job Manager touch

Fly touch

Date Setup touch

Time: 5:54 pm touch

Adjust time



The time is not marked!

It is important for changing the date. The current date affects the marker!

Adjust date



Date: 1/30/03 touch

Check that the date is correct!
Adjust it if necessary

The current date affects the marker!

User number

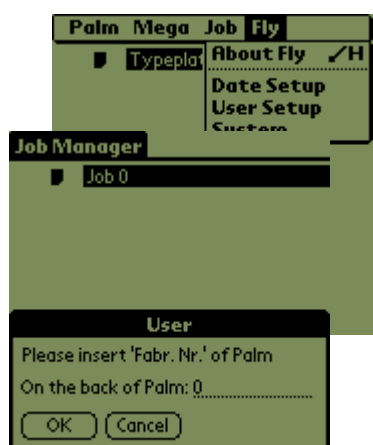

User Setup touch

Enter the factory number of the hand-held

Has safety functions when transferring data from the palm to the *Mega-Marker*

System Only important for service technicians or after checking with our service hotline.
May possibly cause data loss!

Job management

A few tips to make life easier

Palm Mega Job Fly

This bar offers functions for rapid access to changing certain parameters of existing jobs:



These buttons are only significant if a job has already been created. They give you direct access to various settings without having to scroll through the individual job menus.

Scaling ✓S

Do not make any changes in this sub-menu.

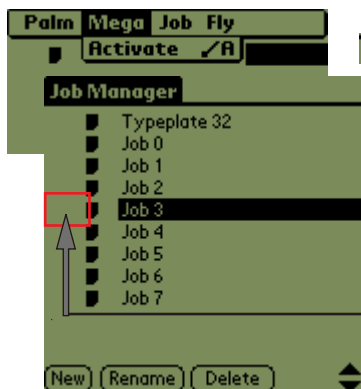

Activate ✓A

Transfers (activates) an existing selected job to the marker.

To select, just touch the corresponding job.

You can also transfer (activate) a job by touching the area marked in red.

Rename

You can give every job its own name, e.g.: **Typeplate 32**



You want to get working with your *Mega-Marker* as quickly as possible, so we are not going to bother you with pages of explanations about the menu. Instead, we are going to create a new job together. This will then explain certain aspects automatically.

Creating a job

Basic aspects of marking

General statements are made in black print.

Red print refers to safety instructions or important information.

Blue print gives you instructions to be carried out.



New touch to open the first job.

All blocks making up a job are managed, changed or deleted here.

Done Confirm entry > next page

New Create a new block

Edit Edit an existing block

Delete

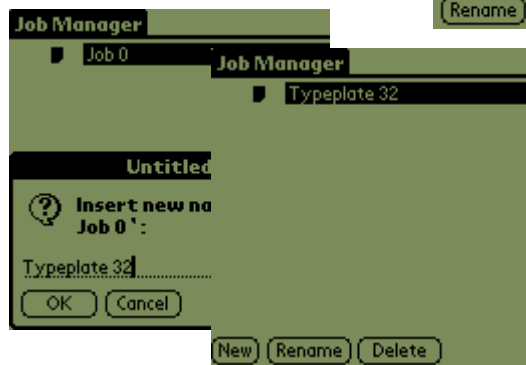

Rename touch

Give the job its own name and press **Done** to confirm.

Done



New touch

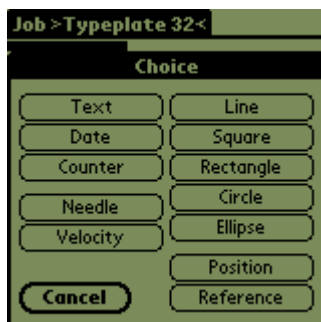

This opens the main selection of individual box options, divided into:

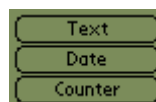

Text block



Graphic block

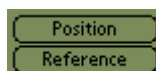

Position block

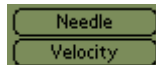

Parameter block

Let's look at the text block first

Creating a text block

Also applies to counting and date blocks.

We want to mark „Test 12345“

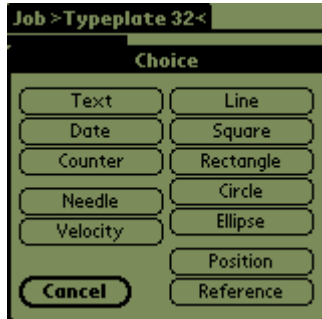

touch



takes you one page back



touch the dotted line
to activate the cursor

The parameter settings
only apply to the corresponding block.



Press „abc“ to activate the keyboard



Enter the word T e s t



Box „Int'l“ activates umlauts



activate the numbers block



and enter 1 2 3 4 5



After making the input,
confirm with „ready“.

The text is ready, now we want to position the block



Adjusting the text and character parameters

Also applies to counting and date blocks.

Selection menu for the text anchor
 Letter height, width, spacing, italics
 X-position of the text anchor
 Y-position of the text anchor
 Linear Angle Round Mark the text linear, at an angle or in the round

Text height and character width

can be freely scaled

touch

touch
 Touch the contents box to open the keyboard
 Enter the required height with the pen
 Delete input
 Leave menu without any changes
 Confirm input

Character spacing

can be selected in mm or as a % of the letter height.

Proportional: character spacing is entered as a percentage of letter height. Default is 100%, but can be changed individually.

If proportional is „clicked off“, the character spacing can be entered in mm of the text height. Default is 1/10, but can be changed individually.

Caution: the small the text, the smaller the pressure setting at the maintenance unit; also reduce the spacing of the needle to the workpiece!

Text slant

The text can be slanted from -45° to the right (italics) to 45° to the left



ABC

Text slant = 45°

ABC

Text slant = -45°

Default

Default setting (here 0°)

Done

Confirm input

TEACH-IN

Teach-in is the convenient method of moving to the X-Y positions with the marking needle directly above the workpiece and checking the positions.

Caution: teach-in only with connected hand-held! >>> Reset!

Connect the data transfer cable to the 9-pin jack on the back right of the marker (above the pneumatic inlet) and screw tight.

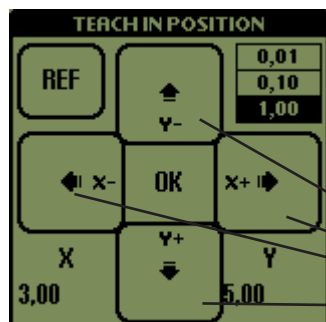

Teach In

You can use teach-in to define the text anchor position with the marking needle directly over the workpiece.

0,01
0,10
1,00

The individual step width can be adjusted from 0.01 mm via 0.10 mm to 1 mm. The current position of the needle is shown under X or Y.

The needle moves in the coordinate cross controlled by the buttons X- Y- X+ Y+.

REF

The needle moves to its „zero position“ top left.



Yes

Adopt position

No

Do not adopt position, new try

Cancel

Do not adopt position, leave menu point



Text anchor

For aligning the lettering in the X/Y position:



- linear - beginning / middle / end of the text
- at an angle - here the text is turned around the selected point
- in the round - this is where the imagined line from the middle of the circle to the beginning/end of the text or of the text alignment stops

The text anchor consists of nine imagined points surrounding every character, text, number or date.

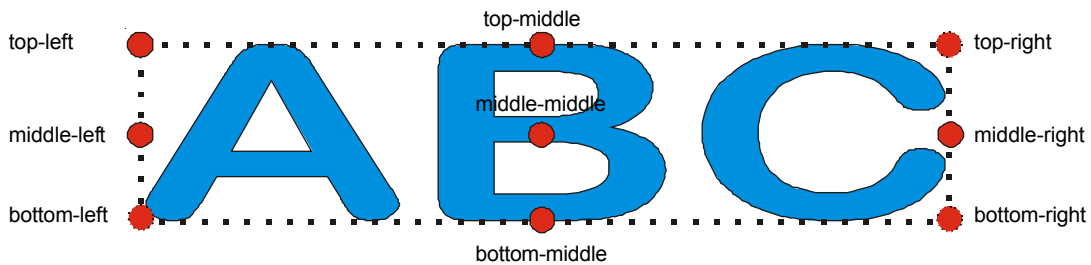

Aligning the text anchor to the X/Y position

Examples: linear text:
X = 5mm / Y = 3 mm constant
Text anchor = variable

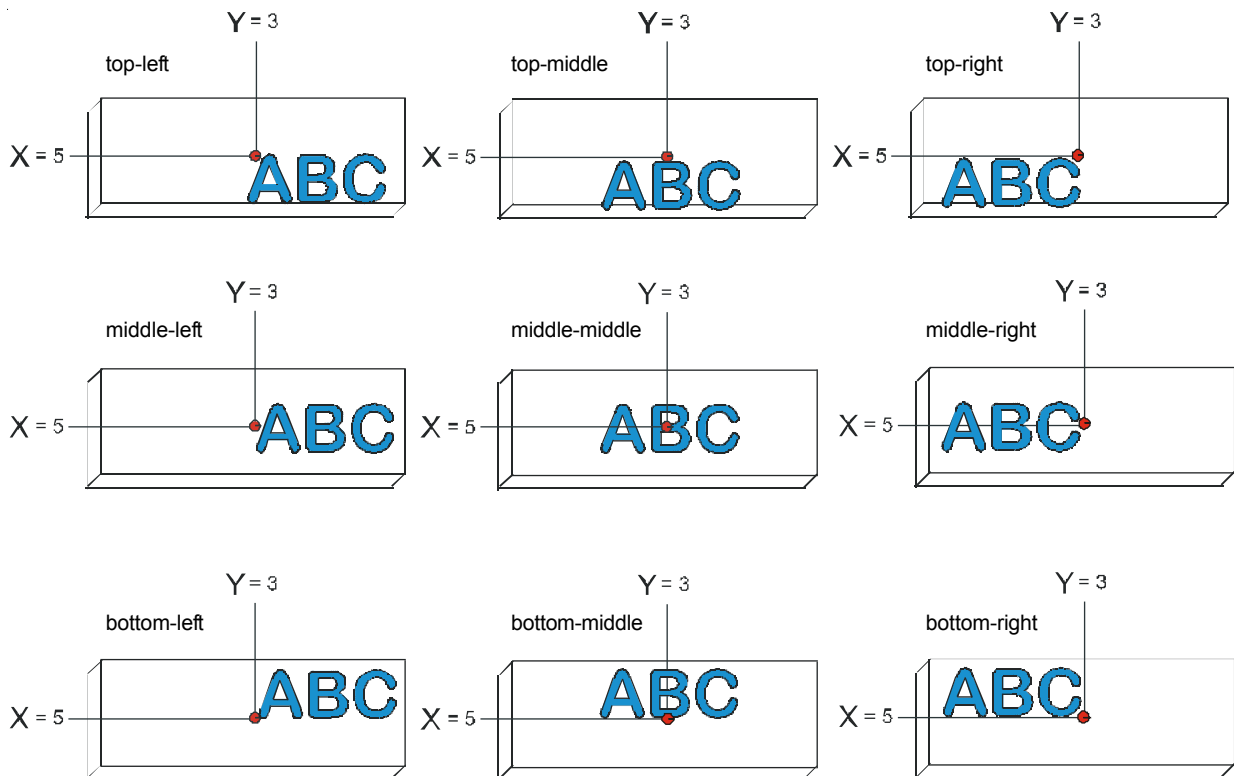

Text anchor – at an angle

Turning the text around the text anchor (e.g. middle – middle)

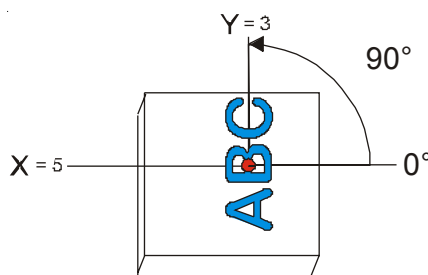
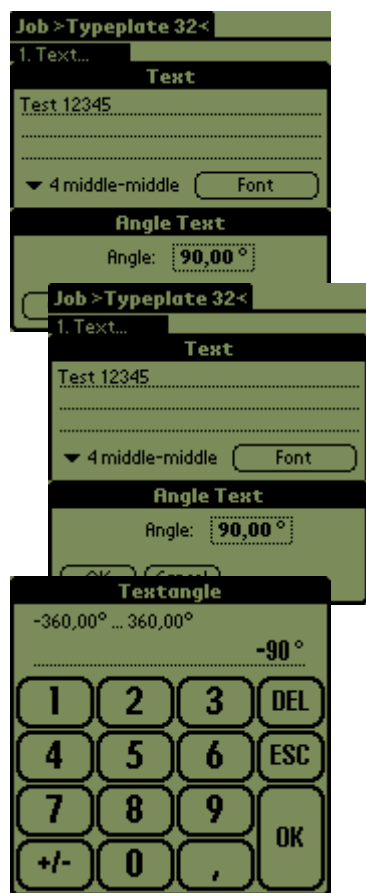

Example:
X/Y position / anchor constant,
variable angle of rotation

angle of rotation = 90°

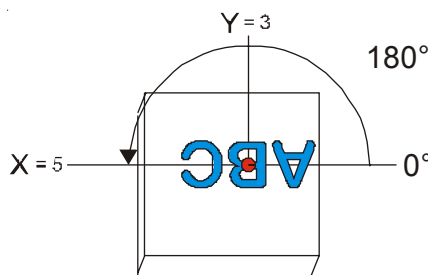

angle of rotation = 180°

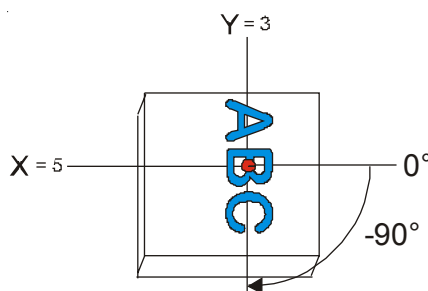

angle of rotation = -90°

Align the text anchor at the constant X/Y position.

Example: X = 5 mm / Y = 3 mm, angle 5°; text anchor = variable

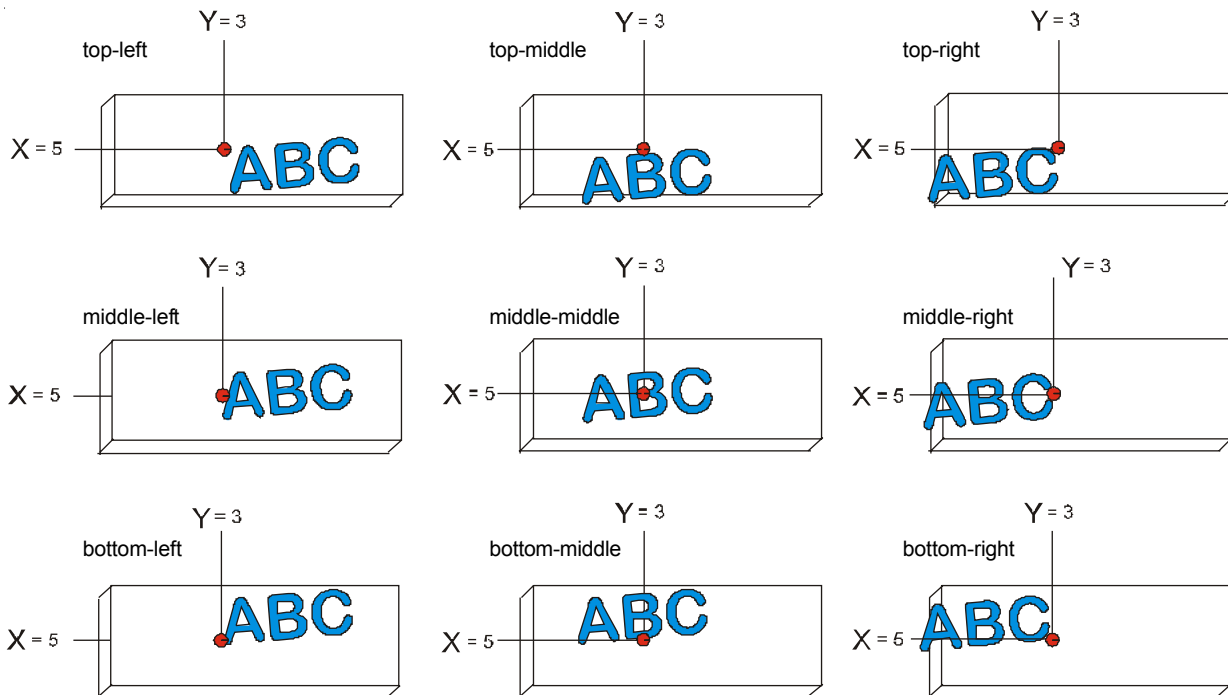

It is possible for the text to be outside the workpiece.



Text anchor - in the round

For printing in the round, the „linear“ or „angled“ text is bent around the text anchor in the round, depending on the position in the coordinates box.

There are two possibilities:

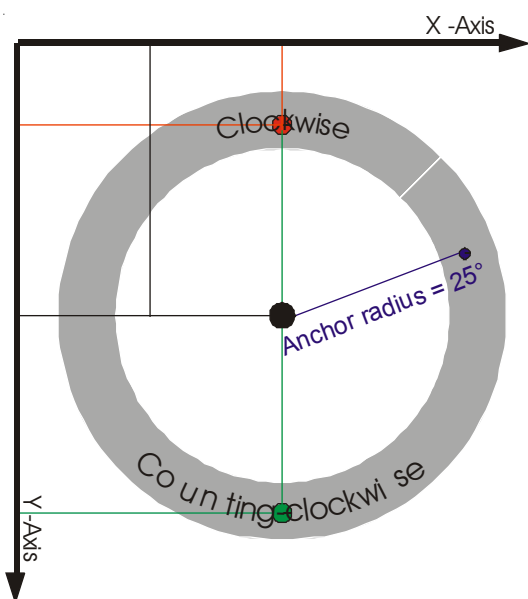
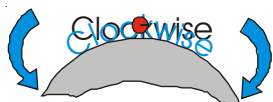

1st text:
anchor point:
middle - middle
X = 40 / Y = 15

Middle point:
X = 40 / Y = 40

2nd text:
anchor point
middle - middle
X = 40 / Y = 65

Text anchor: middle-middle
Recommended for beginners!

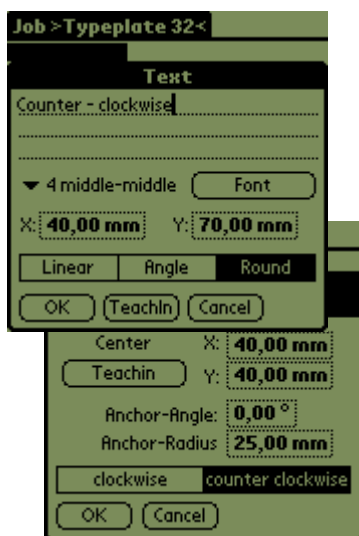
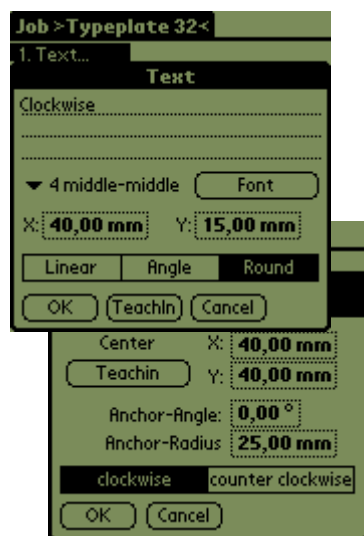
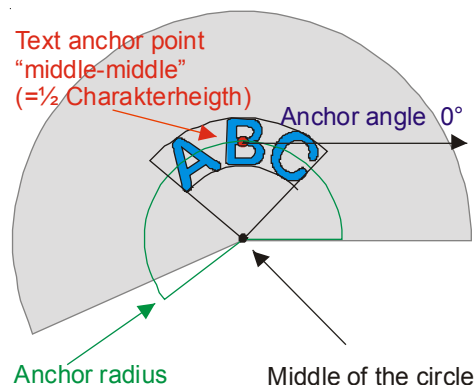

Note the right order:

1. Enter text
2. Select anchor point
middle-middle (*recommended!*)
2. Position anchor point /
teach in
3. Touch in-the-round
4. Choose clockwise or
counter clockwise
5. Anchor angle
6. Radius

Or

5. Teach in middle point

Create your own text, counting or date block, depending on the direction of writing.

Text anchor – in the round

Changing between clockwise and counting-clockwise can only be successful by changing a parameter, as shown below:



In the following examples, please note:

1. the text anchor ●
2. the anchor angle ↙
3. the middle of the circle ●

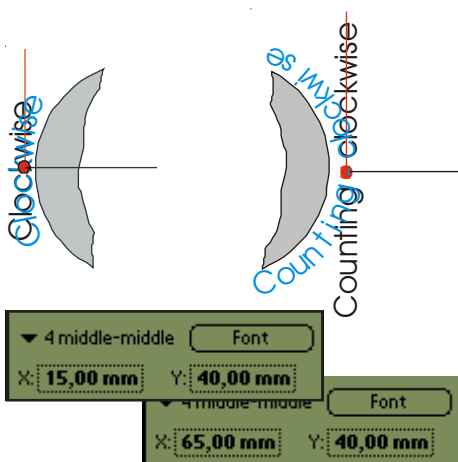

1. Text anchor: **X/Y position offset from X=15 to X=65**
2. Anchor angle: 90° unchanged
3. Middle of the circle: unchanged

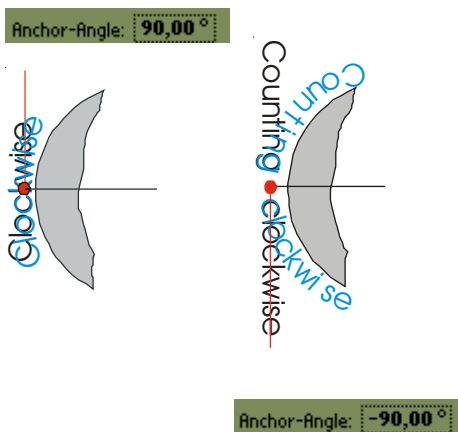

1. Text anchor: unchanged
2. Anchor angle: **turned through 180° from 90° to -90°**
3. Middle of the circle: unchanged

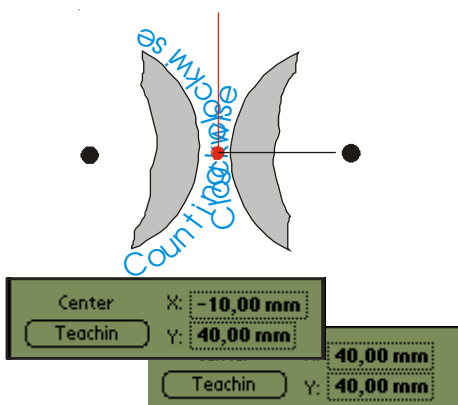

1. Text anchor: X/Y position unchanged
2. Anchor angle: 90° unchanged
3. Middle of the circle: **moved from X=-10 to X=40**

Text anchor – in the round

The anchor points middle -... in the round:

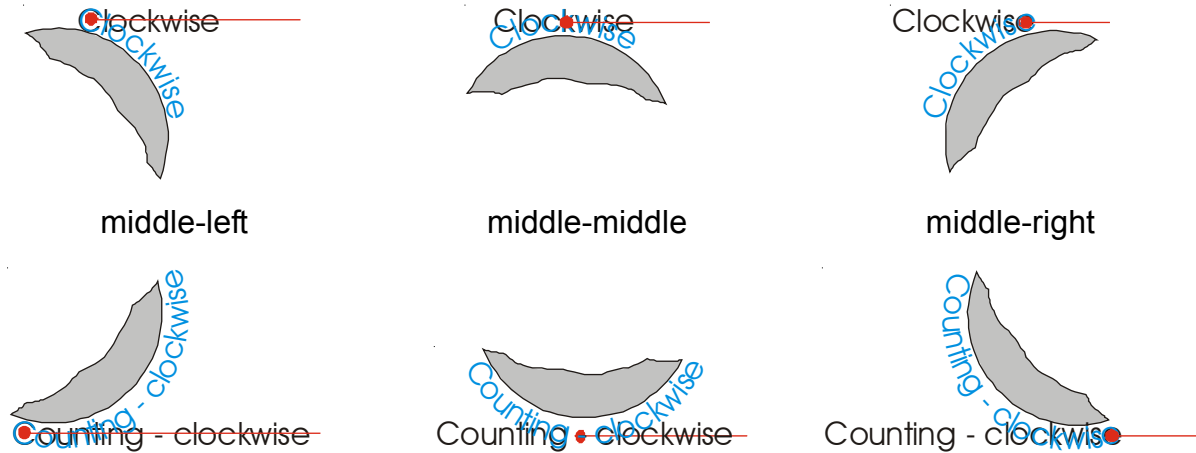

In these examples, the text anchor was changed regardless without paying attention to the other parameters.



Change from clockwise to counting-clockwise, changing the anchor angle:

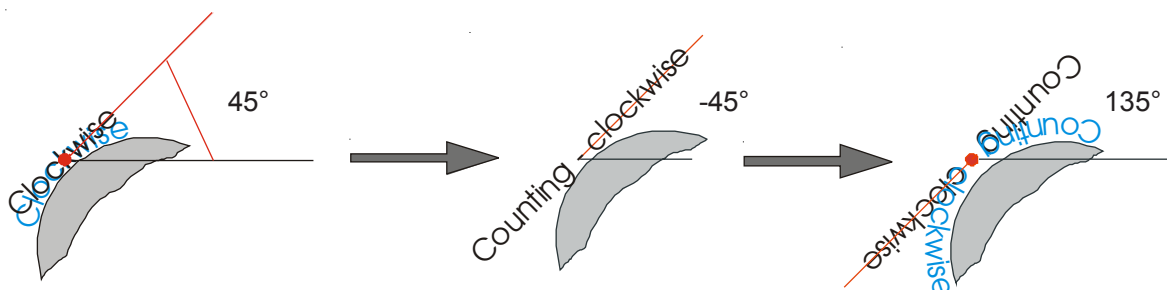

Summary – in the round:

1. Use the text anchor middle-middle (that's the easiest)
2. Use clear angles: 0°, -45°, -90°, -135°, 180°; 45°, 90°, 135°, 180°
3. When changing from „clockwise“ to „counting-clockwise“, the parameters change.

Creating a date block

The date is an independent block.

It can be managed as an independent job, positioned before or after a text, counter etc.

If it is managed as an independent job, start the job management with **New**.

If it is going to be positioned next to a text or counting block, select „date“ in the main menu

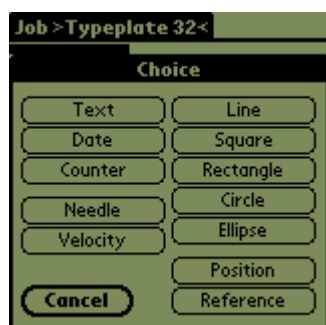

Date touch



31/12/2002 ↑
31/12/02
365 (julian.)
51 (KW)

Select data format
Shows the date format
(not the current date!)



Setup Check current date
(Time is not marked)

Done Confirm entry

Palm->Mega Synchronise date with marker
(Hand-held must be connected to the marker!)

Cancel Reject entry

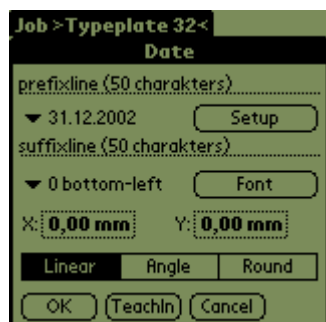

Possibly enter prefix/suffix

Enter or teach-in text anchor, lettering height/width and text anchor position
Select linear, at an angle or in the round

Done Confirm input

Creating a counter

Consecutive numbering

Like the date, the counter is an independent block and can be integrated in an existing job or managed as an independent job.

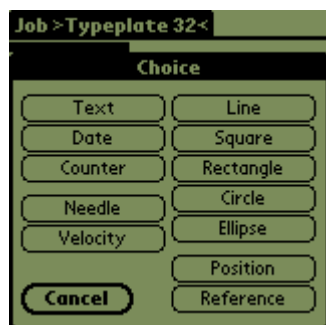

Counter touch



Style touch



left **right** choose flush left/right

Character: 0 choose filler

filler „0“ is not active for flush-left!

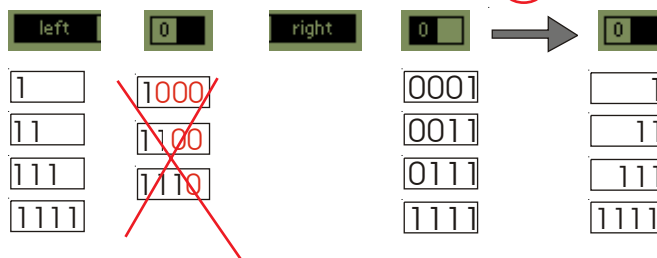

At least: 4 Chars choose character

Following reason:

If you are working with prefix and suffix, there is enough space when changing over from single to multi digit.

If no minimum character set is chosen, the change is made but the number width is smaller.

Creating a counter

Consecutive numbering



 touch

Counter setting:

Possible counting range:

from – 1,000,000 **to** 1,000,000.

A minus sign is marked in the minus range.

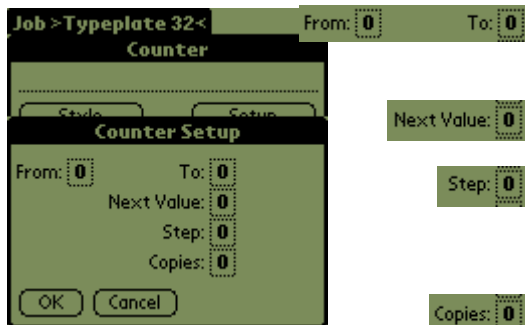

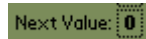
 Value for starting the counter

 Counting increments

e.g.: 1 – 2 – 3 – 4; 2 – 4 – 6; 3 – 6 – 9; 4 – 8 – 12;
Minus sign: counter counts backwards

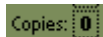
 How often the same number is to be marked

 Confirm input

 Reject input

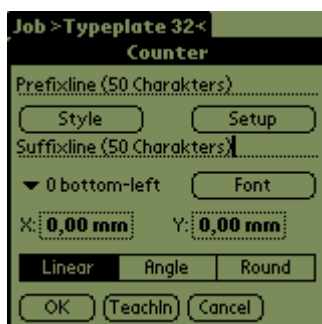

Possibly enter prefix/suffix

Enter or teach in the text anchor, number height/
size and text anchor position

Choose linear, at an angle or in the round

 Confirm input



The job is gradually taking on form.

You can create another text block,
date block or counting block.

Or what about a graphic element?

Creating a graphic element

With the graphic function for example you can put a frame around a text block, date block or counting block, or around all the blocks

Line

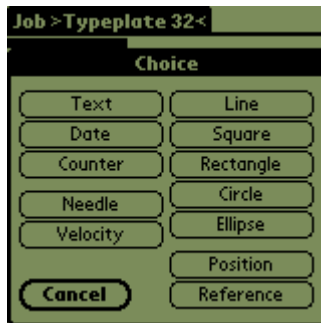

A line can be drawn as required from an X/Y position to another X/Y position in the coordinates field.

Easiest with

touch

Enter or teach in the X/Y starting position, and enter or teach in the X/Y end position in mm.

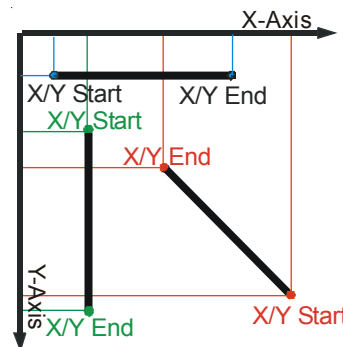
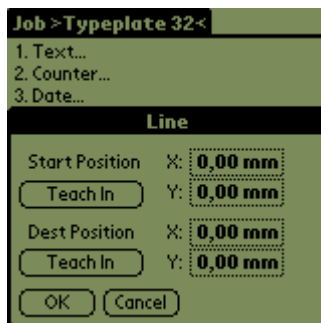

Square

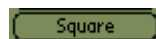
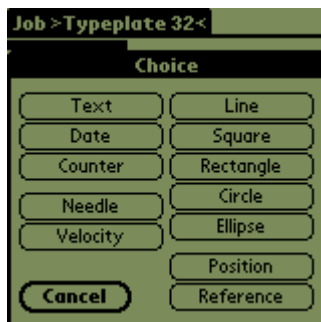

touch

Enter or teach in the X/Y anchor position and enter the side length in mm.

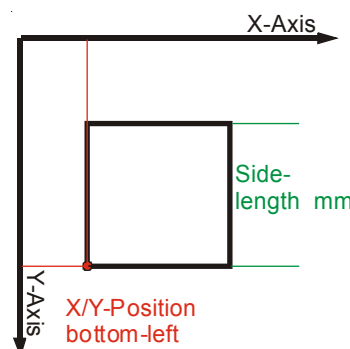
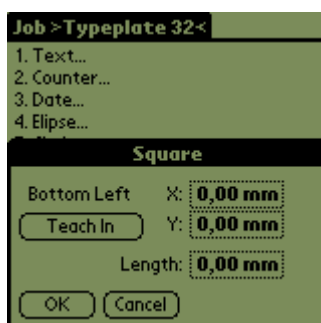

Creating a graphic element

Rectangle

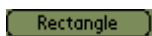
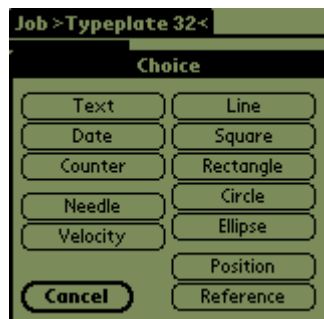

touch

Enter or teach in anchor position X/Y bottom left and enter or teach in anchor position X/Y top right.

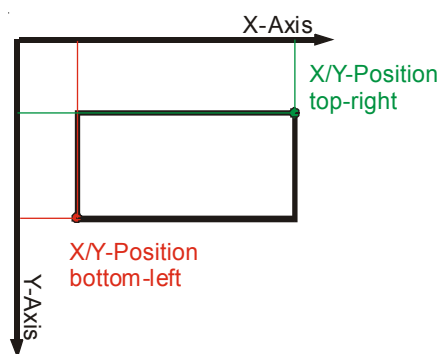
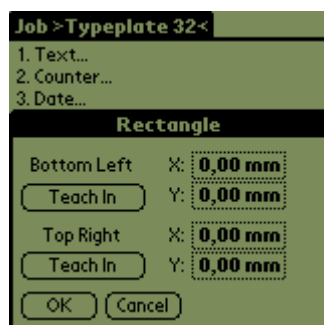

Circle

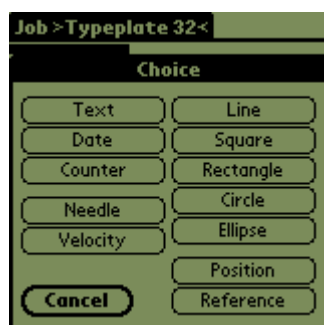

touch

Enter or teach in X/Y position middle point and enter diameter in mm.

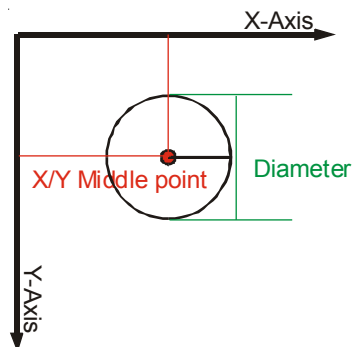
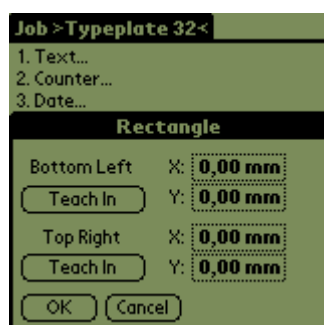

Creating a graphic element

Oval

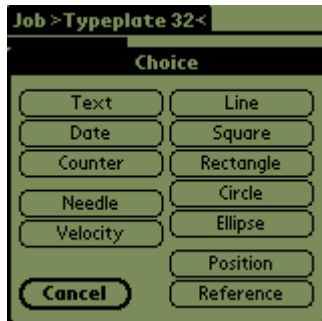

touch

Enter or teach in X/Y position middle point, enter diameter X and diameter Y in mm.

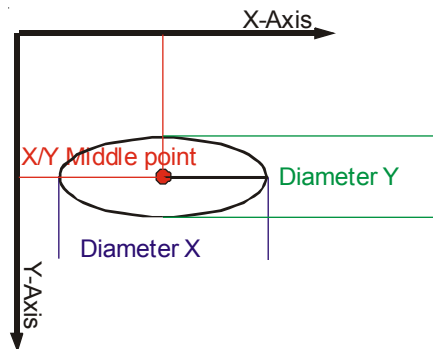
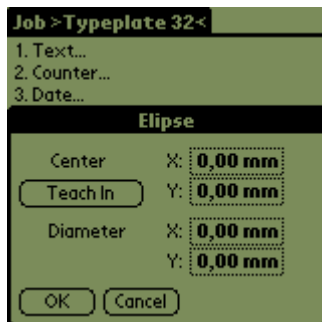

Adjusting the marking parameters

Do you want a fast marking or good lettering?
Of course you can compromise too!

Press **Done** to confirm all inputs, this takes us back to the management of our first job.

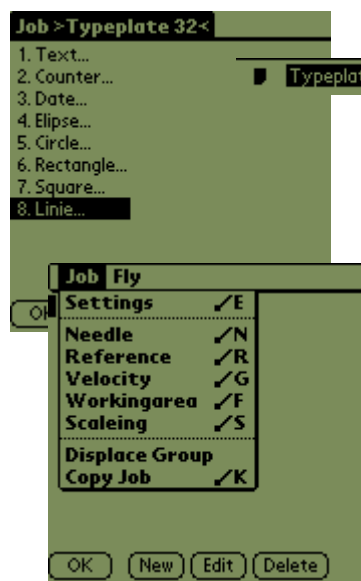

Job Fly

- Settings ✓E
- Needle ✓N
- Reference ✓R
- Velocity ✓G
- Workingarea ✓F
- Scaleing ✓S
- Displace Group
- Copy Job ✓K

Buttons: OK, New, Edit, Delete

Settings no function here

Needle Frequency, pulses, times

Velocity marking speed, reference speed

Workingarea Size of the working range

Scaleing **Please do not make any adjustments!**

Displace Group „move it all 0.76 mm to the right and 0.13 mm down, then it will fit!“

The parameters of the hand-held are in the basic setting. This setting has proved to be a good compromise between fast and good after a large number of trial markings.

Needle



Needle

Frequency: 80,0 Hz

First Impuls: 1,0 ms

Follow Impuls: 2,9 ms

Delay Start: 1,0 ms

Delay Stop: 1,0 ms

Buttons: OK, Default, Cancel

Needle touch

Frequency: 80,0 Hz

The high the frequency, the more dots,
the lower the frequency, the fewer dots

High frequency 

Low frequency 

At the moment, the other parameters do not have any major importance (as of 02.02.2003)

Reference run

You can adjust the direction of the reference run according to your workpieces:

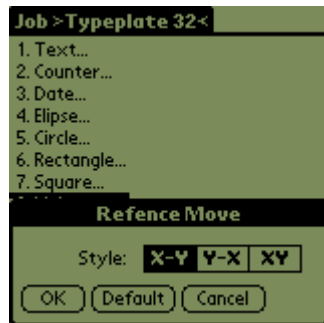

Reference touch
and choose

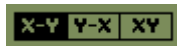

direction X-Y

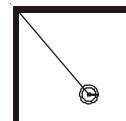

direction 1. Y, 2. X

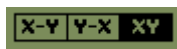
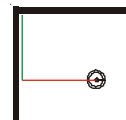

direction 1. X, 2. Y

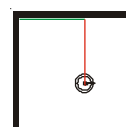

Marking speed

Recommended max. speed 60 mm/sec.

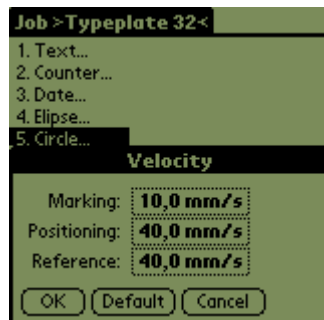

Velocity touch

High speed

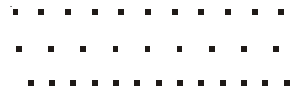

Low speed



Marking: Marking speed: 1 – 80 mm/sec.

Positioning: Moving time between vectors

Reference: Moving time to the reference point

Working area

The standard working area is set to the max. size of 100 x 100 mm

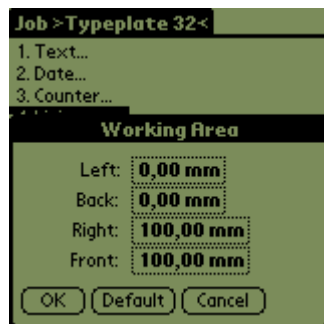

Workingarea

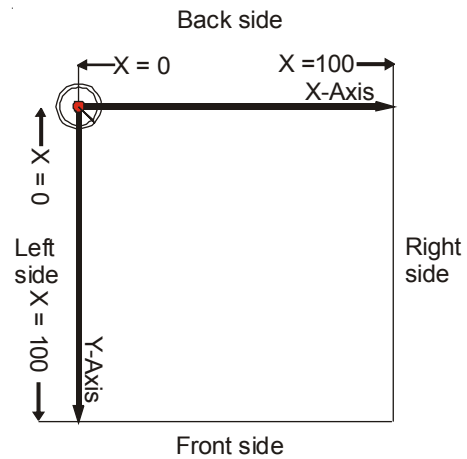

You can reduce the working range for example to match the size of a nameplate

Positioned at the zero point

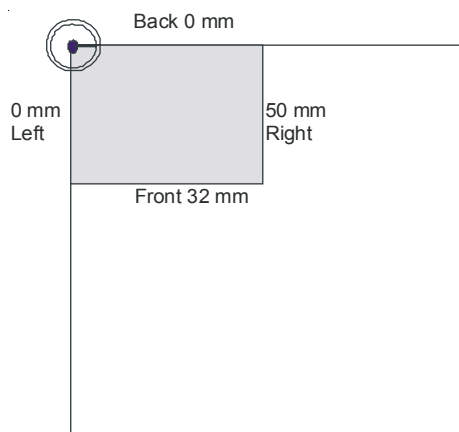

Positioned at any random point

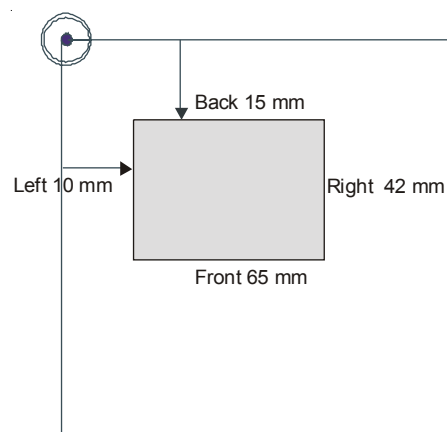

Moving the group

If the text does not yet appear exactly at the required point (e.g. measuring inaccuracies, etc.), individual blocks or the entire blocks can be moved.

Displace Group touch

From Field 0 choose block/blocks
To Field 0

Offset X: 0,00 mm
Teach In Y: 0,00 mm
enter or teach in new value

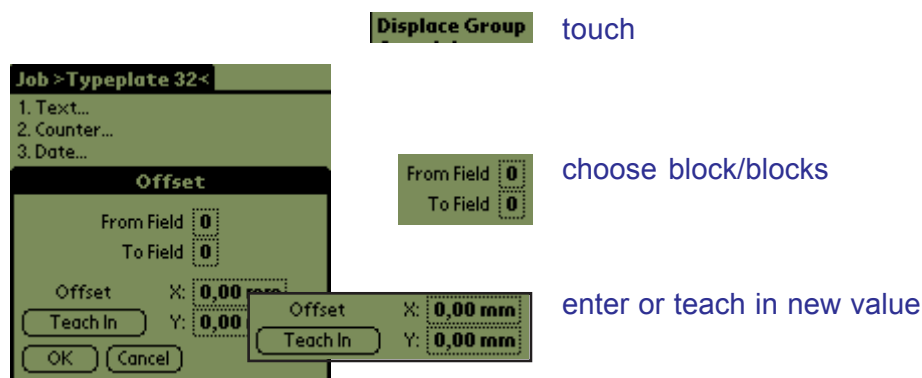

example:

Typenschild 32
Hersteller: EGO
Serien Nr.: 4712
Baujahr: 2002
Prüf Nr.: 1012

Text too far to the left and too far down
(should be in the middle)

Typenschild 32
Hersteller: EGO
Serien Nr.: 4712
Baujahr: 2002
Prüf Nr.: 1012

Enter new values (X / Y)

Typenschild 32
Hersteller: EGO
Serien Nr.: 4712
Baujahr: 2002
Prüf Nr.: 1012

All blocks moved

Approaching positions

The needle moves directly to the first block to be marked.
It is possible for the workpiece to have a bump in the way.

Example:

This workpiece has two bumps.
A marking block is to be applied parallel to each bump.

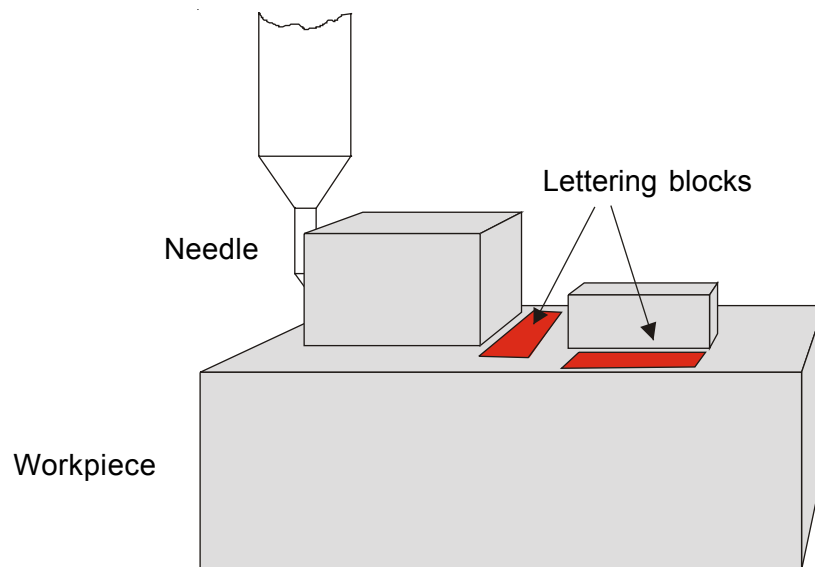

- Steps required:
1. Diversion position
 2. Text block at an angle
 3. Diversion position
 4. Linear text
 5. Diversion position
 6. Diversion position
 7. Reference run

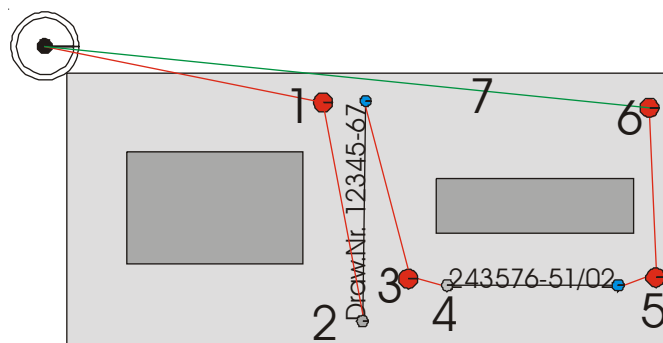

Let us create a new job for this task:



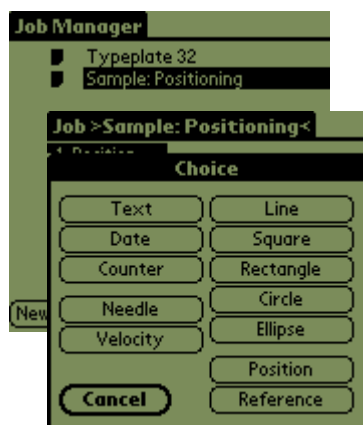

You remember:

1. Job management: create a new job.
2. Rename the new job
3. Touch the page symbol in the job management
4. In Job, select „new“
5. In the selection menu, touch **Position**

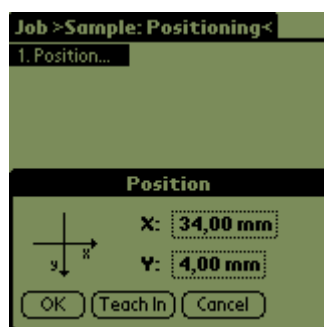

Enter or teach in position 1
Press **OK** to confirm

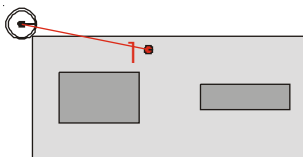

In Job, touch **New**
In the main menu, select **Text**
Enter text,
choose text anchor here: bottom left
Define lettering size
Define text anchor position (teach-in)
Adjust angle setting (here **OK**)
Press **OK** to confirm

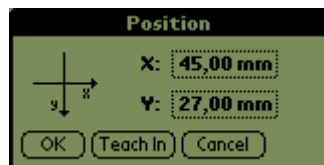
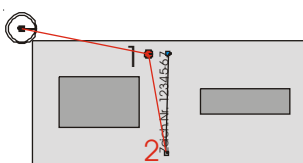

In Job, touch **New**
In the main menu, select **Position**
Enter or teach in position 3
Press **OK** to confirm

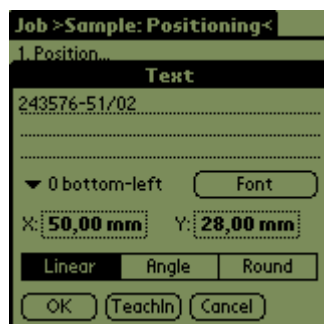
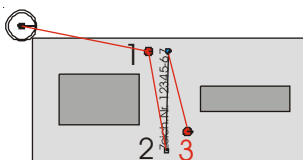

In Job, touch **New**
In the main menu, select **Text**
Enter text,
choose text anchor here: bottom left
Define lettering size
Define text anchor position (teach-in)
choose **Linear**
press **OK** to confirm

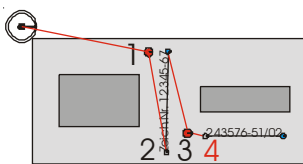

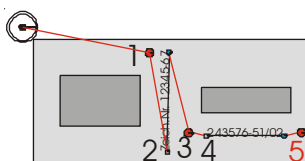
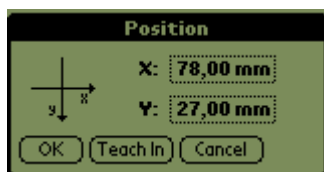

In Job, touch **New**
In the main menu, select **Position**
Enter or teach in position 5
Press **OK** to confirm

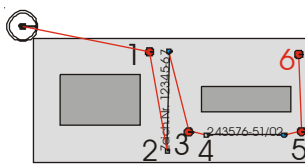
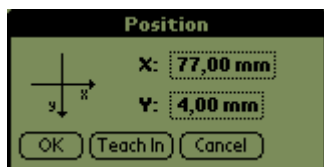

In Job, touch **New**
In the main menu, select **Position**
Enter or teach in position 6
Press **OK** to confirm

Reference run

The needle always stops after the last text, date or counting block. It is advisable to include a reference run at the end of a job.

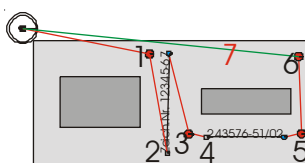

In Job, touch **New**
In the main menu, select **Reference**
Enter
Press **OK** to confirm

And this is your finished job.

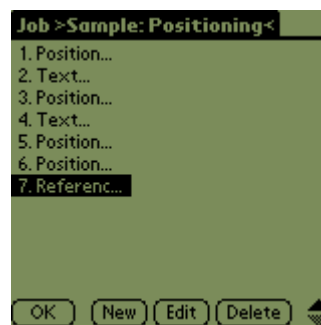

What does the marker do?

The needle moves from the zero point to position 1,
moves from here to the 1st text anchor point (2)
marks from to ,
moves via position 3 to the 2nd text anchor point (4)
marks from to ,
moves via position 5 and 6 and concludes with reference run 7 back to the zero point.

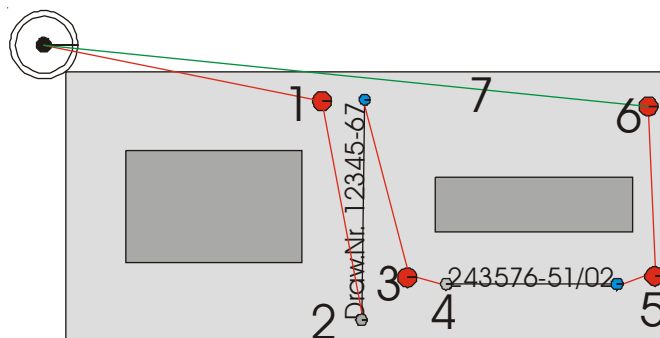

Transferring the job to the marker

The individual jobs are managed in the hand-held.

Only one job - the active one - is saved in the memory of the marking head.

This active job is performed until another job is transferred to the marker.

There are two ways of transferring a job to the marker:

The hand-held **must** be connected to the marker and the marker must be switched on!!

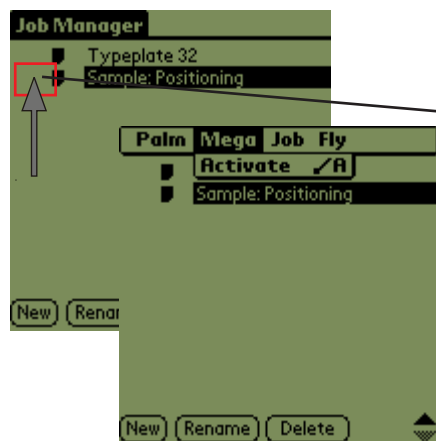

1st way:

Touch the job so that it is marked black, use the input pen to touch the box framed in red here.

2nd way:

Touch the job so that it is marked black, touch the menu bar **Job Manager**, touch **Mega**, touch **Activate** ✓/A

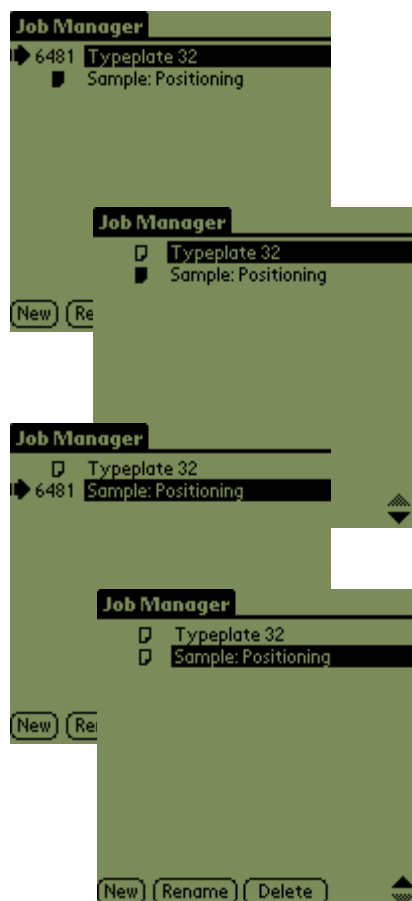

When the job is activated in the marker, the marker answers with its factory number (here: 6481)

To deactivate the job, touch the arrow before the number

After deactivating the job, the number goes away again.

The pale page symbol indicates that the job was in the marker.

As long as the number before the job can be seen, this job cannot be used.

Not even when the hand-held is disconnected from the marker.

To transfer a new job to the marker, deactivate the existing job and activate the next one.