



Operating instructions SIGNOMAT S2000 and pneumatic workholder

Schilling
Marking Systems GmbH
In Grubenaecker 1
D-78532 Tuttlingen-Germany
Tel. +49 (0)7461 9472-0
info@schilling-marking.de
www.schilling-marking.de

A INTRODUCTION

Dear Customer,

You have made a good choice by purchasing a Signomat S2000 Marking System. Thank you for your trust in our product. Your system will honour this trust, but there will be one condition to satisfy right from the onset: The system should always be treated with respect, even under the most ardent of conditions. Consequently Operating Instructions should be kept with operators.

It would be a mistake to have these Operating Instructions rot away under heaps of dust. We have therefore endeavoured to give you all the recommendations and information necessary for operating, servicing and monitoring your system.

Please read these Instructions carefully PRIOR TO COMMISSIONING the system in order to become familiar with them.

Following these Instructions precisely will save you time and prevent losses, and you will still be fully satisfied with the system's performance in years to come.

We wish you success in your work and optimum results by employing your SCHILLING System.

Thank you for your attention and have a good start!



B Contents

A	INTRODUCTION	2
B	Contents	3
C	Safety instructions	4
D	Scope of applications	4
E	Specifications	4
F	Manufacturer information	4
F.1	Alterations	5
F.2	Confidentiality	5
G	Transport, installation and start up:	5
H	Machine, pneumatic workholder and control elements	6
I	Working with the Signomat S2000	7
J	Working with the accessory equipment	8
J.1	Connecting cables	8
J.2	Connecting the electrolyte hose	8
J.3	Positioning the workpiece and stencil	8
J.4	Electrolyte flow	8
J.5	Regulating contact pressure	8
J.6	Trial operation	9
J.7	End of marking procedure	9
J.8	Improving marking results	9
J.9	Short circuits	9
J.10	Servicing and maintenance	9
K	Use of Electrolytes	11
L	Ordering carbon stamps and stencils	13
M	Appendix	14



C Safety instructions

When used properly, the SIGNOMAT S2000 is operationally safe. Still, a few points should be noted for the handling of chemicals:

Use rubber gloves.

Eyes must be protected against electrolyte, neutralyte and preserving agent. Should eyes come into contact with the chemicals, immediately rinse eyes thoroughly with clear water and contact a physician.

Do not swallow electrolyte, neutralyte and preserving agent. Should electrolyte be swallowed, immediately drink a large glass of clear water and contact a physician.

Should skin or clothing come into contact with the chemicals, rinse immediately with water.

Eating or drinking at the workplace is prohibited.

Hands must be washed before eating.

Electrolyte may be disposed of in the normal sewage system.

Keep children clear of the machine.

Use the Signomat S2000 in dry locations only.

Ensure correct mains voltage (230 volts or 115 volts, see nameplate).

Keep explosive gases clear of the machine.

Disconnect the mains plug before opening the machine. Most points at which danger of injury exist have been eliminated. However, please take care to keep hands away from the pneumatic workholder during the working and return strokes. Never short-circuit the sockets by connecting two sockets by a cable. The overcurrent circuit breaker responds, but the machine may still be damaged under certain conditions.

D Scope of applications

The equipment is designed exclusively for marking metallic objects. Proper function and a reproducible result is guaranteed only when Schilling accessories are used.

E Specifications

Type:

Serial Number:

SIGNOMAT S2000

see nameplate

Year of manufacturing:

see nameplate

Dimensions:

W x L x H

362 x 150 x 315 mm

Operating voltage:

115/230 V 50/60 Hz

Marking voltage:

12 V/18V/24V

Type of mark:

light/dark

Rate power:

300 VA

Weight:

12,5 kg

Fuse:

2 AT

Noise level:

20 dB

Type:

Pneumatic workholder

Factory number:

see nameplate

Year of manufacturing:

see nameplate

Dimensions without electrolyte bottle:

W x L x H

260 x 380 x 532 mm

Weight:

approx. 12 kg

Vertical stroke of stamp:

50 mm

Air consumption per stamping procedure:

0.075 l

Range of opt. working pressure:

2.5 - 3 bar

Max. operating pressure:

6 bar

F Manufacturer information

Schilling

Marking Systems GmbH

In Grubenaecker 1

DE-78532 Tuttlingen-Germany

Telephone: +49 (0)7461 9472-0

Fax: +49 (0)7461 9472-20

eMail: info@schilling-marking.com

URL: www.schilling-marking.com



F.1 Alterations

Technical alterations reserved. Your machine may therefore deviate in details from the illustrations in the manual. This does not affect the operation of the machine.

F.2 Confidentiality

These operating instructions are to be treated confidentially. They have been provided only for use in your operation by authorized persons. The transfer of this document to third parties is prohibited and results in damage claims. All rights, including the right to translation, are reserved.

G Transport, installation and start up:

Please keep the packaging for re-use during transport. Ensure that all accessories are packed, too and that bottles of chemicals are well sealed. Should chemicals run out, wipe up by using rubber gloves, cleaning rags and water. See safety recommendations in Chapter A.

Check whether your mains voltage corresponds with the voltage stated on the rating plate. Connect the Signomat by the mains cable 15 to a mains socket. Connect the carbon stamp (9 or 50) to the black cable 21 and to the black socket of the system. Then connect the red cable 20 to the red socket 13 and to the red fixture 59 or the red socket on the contact plate. Check whether the hand stamp 9 is equipped with a felt and O-Ring 17. Then wet the felt with a little electrolyte.



H Machine, pneumatic workholder and control elements

- 9 manual stamp
- 10 contact clamp
- 12 Y1 connecting cable from Y1 contact socket 11
of the Signomat to the pneumatic workholder (without electrolyt pump)
- 14 foot switch with cable and plug
- 15 mains cable
- 17 felt piece and O-Ring
- 20 red cable
- 21 black cable
- 24 locking screw, workpiece pick-up for transfer adjustment (x-axis)
- 25 knurled screw, workpiece pick-up for longitudinal adjustment (y-axis)
- 26 knurled screw, workpiece pick-up for horizontal rotation adjustment
- 27 knurled screw for stop
- 28 knurled screw for stencil holder spring
- 29 knurled nuts for longitudinal stencil adjustment (y-axis)
- 30 knurled nuts for transverse stencil adjustment (x-axis)
- 31 knurled screw for stencil height (z-axis)
- 32 knurled screw for horizontal rotation adjustment of stamp
- 33 lever for height adjustment of marking arm
- 34 electrolyte pump (special accessories, item no. 35.005. For maintenance and adjustment, see
separate pump instructions)
- 35 socket for Y1 connecting cable 37
- 36 socket for connecting cable 55
- 37 Y1 connecting cable from pump case (socket 35) to Y1 contact socket 12
of the Signomat
- 38 pump: supply pumps, automatic metering of electrolyte
- 39 pump: fast supply
- 40 pump: fast return
- 41 controller for amount to be metered
- 42 electrolyte hose (pump), item no.35.220
- 43 pump wheel
- 44 clamp
- 45 pressure reducing valve with manometer
- 46 oiler
- 47 regulating screw on oiler
- 48 condensate delivery screw
- 49 magnetic valve
- 50 stamp
- 51 felt piece
- 52 workpiece pick-up
- 53 marking stencil
- 54 O-ring
- 55 connecting cable from pump case (socket 36 to magnetic valve 49)
- 56 socket on magnetic valve for cable 55
- 57 manual injector (electrolyte hose: item no.34.274)
- 58 compressed air hose for connection to a compressor air line
- 59 marking head
- 60 bottle, item no.35.813
- 61 hollow needle, item no.35.810
- 62 felt case for automatic felt transport (accessory equipment; requires compressed air
connection, item no.11.130)



I Working with the Signomat S2000

Smaller workpieces can be placed directly on contact plate. Select the correct electrolyte for the metal of the workpiece according to the provided table, and the recommended marking time. Carefully and evenly moisten the felt piece on the stamp and the stencil with the selected electrolyte. The felt must be evenly moistened with the electrolyte and should not drip. Position the moistened marking stencil with the desired text on the workpiece. Press the manual stamp downward vertically, ensuring that the entire surface contacts the stencil evenly. If foot switch 14 is not used, the marking current is now automatically switched on. If foot switch 14 is used and connected to socket 13, marking current is switched on only after the stamp has made contact with the workpiece and foot switch 14 has been activated.

Wipe away remaining electrolyte using a cloth moistened with neutralyte. Metals which corrode are neutralised by neutralyte N2 and protected by preserving agent K1. The electrolyte suitable for the workpiece material used is listed in the provided table.

In order to avoid oxidation (rust), we urgently recommend that chemicals are handled with extreme care. Above all, never touch the workpiece with your hands when traces of electrolyte are on your hands (electrolyte may be carried over). For steel with high carbon content, thorough neutralization, cleaning by ultrasound and/or coating with a film of oil or a preserving agent is highly recommended.

To avoid corrosion we are keeping Electrolytes with less corrosion as an alternative!



J Working with the accessory equipment

Contact clamp 10 is provided for marking bulky objects. Clamp the contact clamp onto the workpiece, connect the red cable to the contact clamp and red socket 13, and mark the workpiece using stencil and manual stamp as described above.

Add-on assemblies constructed according to customer specification are additionally available as accessory equipment, and facilitate exact marking by holding the stencil and workpiece in a precisely defined position. Place the workpiece in the workpiece pick-up (exchangeable and constructed according to customer specification on request) of the add-on assembly and adjust the stencil using the adjusting screw. Connect the workpiece pick-up on the add-on assembly to the red socket 13 using the red cable, and mark the workpiece using the manual stamp as described above.

J.1 Connecting cables

The red cable is connected to marking head 59; the black cable is connected to stamp 50. Connect electrolyte pump 34 (accessory equipment) to socket 35 by means of the provided cable 37, and to the Signomat (socket 12). Insert cable 55 in socket 36, and connect to socket 56 on magnetic valve 49.

J.2 Connecting the electrolyte hose

Please observe the safety instructions provided section C when handling chemicals.

If the hose is already connected to the bottle containing electrolyte, the hose must first be removed again from the bottle. The hose should contain no liquid when it is installed in the pump.

Set the distance between pump block and pump wheel as described in the separate operating instructions of the electrolyte pump and using the provided setting ring gauge.

Switch on the Signomat and pump 34 by means of switch 39 (>>supply). Now insert the electrolyte hose into the guide of pump wheel 43 from the left and pull through to the right. Ensure that the length of the hose is sufficient for the movement of the stamp to workpiece pick-up 52. The electrolyte hose should be not pulled too tight. Connect the left-hand end of the hose to electrolyte bottle 60 (containing with hollow needle 61). Caution: the bottle has an air hole through which electrolyte can escape - do not tilt bottle! Connect the right-hand end of the hose to the stamp.

J.3 Positioning the workpiece and stencil

Position felt piece 51 on the stamp from the bottom, and secure using black O-ring 54. Workpiece pick-up 52 is positioned with the workpiece transversely to the stamp by means of locking screw 24. Knurled screw 25 is provided for longitudinal adjustment of the workpiece pick-up. The stop is set by means of knurled screw 27. Loosen knurled screw 28, insert marking stencil and clamp by means of the holding spring at knurled screw 28. The stencil can be positioned exactly by means of the knurled screws and knurled nuts 29, 30 and 31 by loosening the locking screws and setting the turning screws. Stamp 50 can be set at a turned angle by means of knurled screw 32.

The height of the marking arm, and thus the stroke of the stamp can be set by means of lever 33 located at the rear of the machine. The stamp covers a maximum stroke of 50 mm. The length of the stroke does not influence the quality of the resulting mark, but the marking procedure can be shortened by setting as short a stroke as possible. Exact positioning of workpiece pick-up 52, stamp 50 and marking stencil 53 can be checked without exerting pressure by pulling down the stamp when the machine is switched off.

J.4 Electrolyte flow

Electrolyte is transported to the felt piece by means of the electrolyte pump (automatic supply) or the manual injector (manual supply), depending on the construction on the pneumatic workholder.

Automatic supply: Activate switch 39 (>>supply) and wait until the electrolyte has reached the stamp. Then activate switch 38 (>operation) and set the required flow rate by means of controller 41 located on the the right-hand side of the pump. The flow-rate should be sufficient to keep the felt piece on the stamp continuously moistened, but not so great that electrolyte is pressed out of the felt piece during the marking procedure (2-3 bar is recommended). After operating the foot switch on the control unit, the electrolyte pump automatically provides the set electrolyte flow rate for the marking procedure.

Manual supply: Fill manual injector 57 with electrolyte, connect the electrolyte hose and insert the injector in the mount on the front of the marking arm. Metering must be carried out manually at regular intervals.

J.5 Regulating contact pressure

Pressure reducing valve 45 with manometer is located on the left-hand side of the pneumatic workholder. The valve is disengaged by pulling upward; pressure can then be regulated. Look the valve again after this has been done by pressing downward. Next to the valve, oiler 46 is located which supplies the compressed air with oil for the



stroke cylinder. Ensure that the oiler has a sufficient supply of machine oil at all times. Good results are attained at contact pressures between 2 - 4 bar. Pressure must be set higher for marking larger surfaces. Excessive pressure (6 bar) presses the electrolyte out of the felt piece. The resulting mark is not acceptable.

J.6 Trial operation

Position the workpiece and check the settings. When the Signomat is ready for operation, set marking time and type of marking as described in the corresponding paragraphs. Activate the foot switch connected the Signomat and start a trial marking procedure. If the result meets your requirements, serial production can be started. If this is not the case, change the settings as required or check whether the tips given in the section „improving marking results“ would be of help.

J.7 End of marking procedure

When switch 40 (<<return) of the electrolyte pump is activated, the electrolyte remaining in the electrolyte hose and felt piece is pumped back into the container. Switch off machine. Remove felt piece 51 from stamp 50 and rinse both thoroughly with water. If work is to be interrupted for several days, rinse the electrolyte hose with water.

J.8 Improving marking results

Before the first marking procedure, moisten the stencil with electrolyte when current is switched off. Dry felt impedes current conduction, and the resulting mark is extremely poor. Dried electrolyte and neutralyte result in salt deposits in the machine; this also impedes current conduction, causing poor marking results. For this reason, daily rinsing with clear water is necessary. Stencils soiled by metallic residue must be cleaned carefully and at regular intervals. To do this, hold the stencil carefully between two fingers under water and clean. The stamp and workpiece pick-up must also be cleaned with water at regular intervals. In case of extreme soiling, clean with Schilling Schleifreiniger (abrasive cleaner; item n.22.165).

Ensure that the electrolyte suited for the metal to be marked is on hand. Certain materials, e.g. hard metal, must be protected by preserving agent K1 (item no.22.112). Mark small surfaces using the simple pressing method. Mark larger surfaces manually using the stroking method. A working pressure of 2 - 4 bar in the pneumatic workholder provides good results. Use higher pressures only for larger marking images.

To avoid premature wear and to prevent the electrolyte from evaporating, the stencil should not be heated excessively. The material of the stencil heats up to a temperature of more than 120°C. This causes poor marking results. The stencil must then be replaced. In normal operation, the stencils with long service life are good for 2000-3000 marking procedures. Felt which has darkened must be replaced in regular intervals. Bigger marking images cause stronger and faster darkening or pollution of the felt.

J.9 Short circuits

The main fuse is at the rear of the controller. Remove the black cover to withdraw the blown fuse and replace it by the spare fuse supplied. Should the fuse be OK, check mains connection. Should no marking power be available, check whether the cables are kinked and therefore interrupted. If so, immediately replace cables with original Schilling replacement cables.

J.10 Servicing and maintenance

Signomat:

The Signomat is maintenance-free. The stamp, the felt piece and contact plate 16 or workpiece pick-up 52 must be cleaned thoroughly with water after each working day. Stencils have a service life of 2000-3000 marking procedures. Replace the stamp when it shows signs of excessive wear. Replace the stamp when it shows signs of excessive wear. Replace darkened felt pieces. The ordering numbers are provided on the following pages.

Pneumatic workholder:

Clean stamp, felt piece and workpiece pick-up thoroughly with water after each working day. This is essential. Replace worn electrolyte hoses.

Ensure that oiler 46 (next to the pressure reducing valve) is always filled with a sufficient level of acid-free machine oil. Oil flow is regulated by means of the screw mounted on the oiler.

Clean the rollers of pump wheel 43 and oil with resin-free oil.



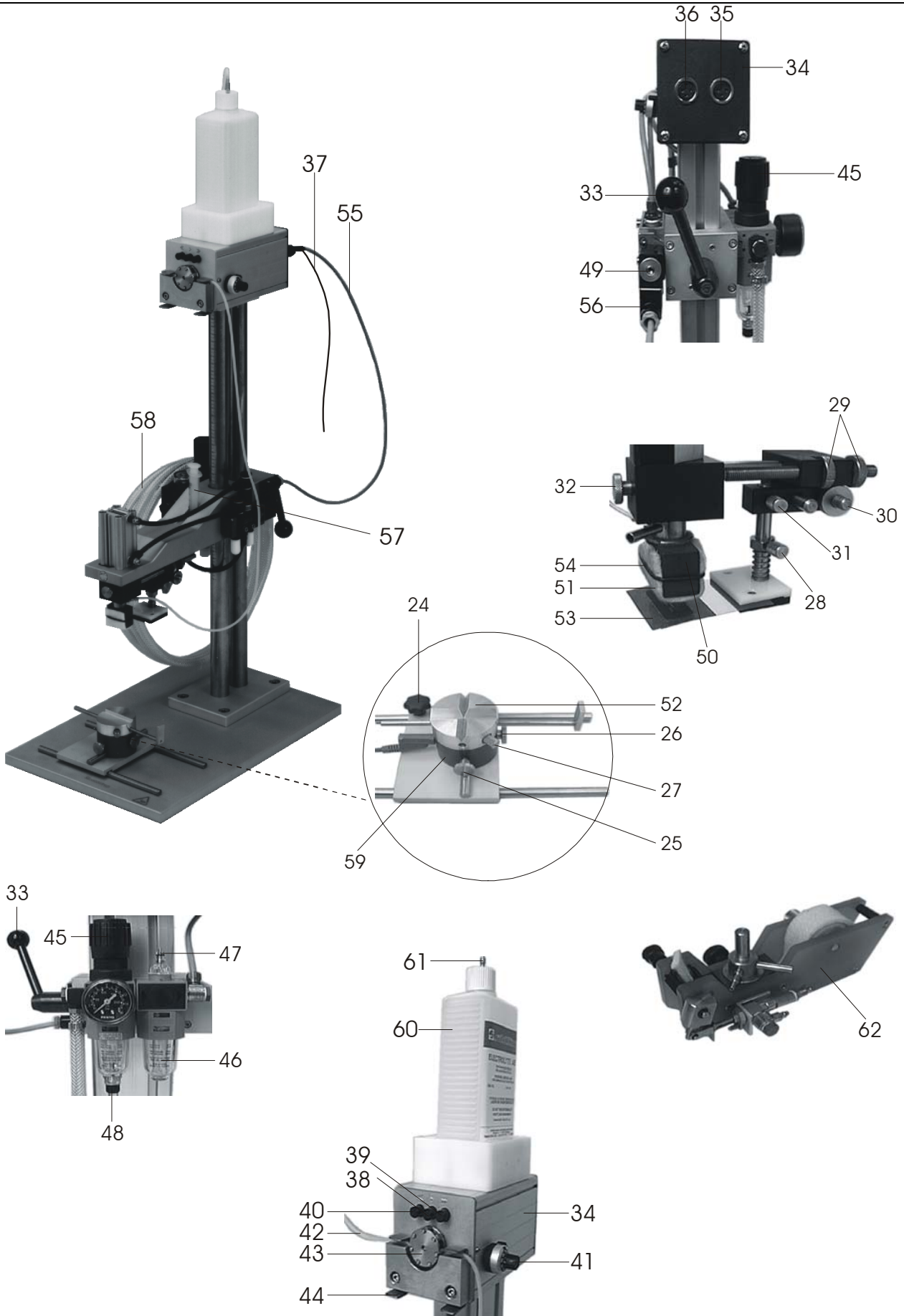

K Use of Electrolytes

All data have been determined by experiment and are not applicable in general. A special hotline has been provided for our customers.

Material, alloys, branch	ItemNo	Electrolyte	Power unit setting/voltage	Notes
Aluminium	22.038	AE38	light/24V	
Aluminium (most alloys)	22.002	AE2	light/24V	Allow a few seconds for color to develop before cleaning
Aluminium with high magnesium or silica content	22.025	AE25	light/24V	Black not possible unless lacquer filled
	22.012	AE12	light/24V	Deep etch BEFORE anodizing (minimum 0.05mm)
Beryllium	22.001	AE1	dark/12V	
Black oxide	22.026	AE26	dark/12V	Current setting: light & dark
	22.030	AE30	dark/12V	Current setting: light & dark
Black oxide steels	22.026	AE26	dark/12V	Current setting: light & dark
Brass	22.037	AE37	dark/12V	
	22.025	AE25	dark/12V	
Bronze	22.037	AE37	dark/12V	
	22.025	AE25	dark/12V	
Carbides	22.021	AE21	dark/12V	
Chrome plate	22.005	AE5	dark/12V	
Chrome plate (decorative)	22.005	AE5	dark/12V	
	22.035	AE35	dark/12V	pH-neutral, low corrosion
Chrome plated parts	22.005	AE5	dark/12V	
	22.024	AE24	dark/12V	
Cobalt alloys	22.037	AE37	dark/12V	
Copper	22.037	AE37	dark/12V	
	22.025	AE25	dark/12V	
Copper alloys	22.037	AE37	dark/12V	
	22.025	AE25	dark/12V	
Copper nickel	22.030	AE30	dark/12V	
CuZn alloys	22.037	AE37	dark/12V	
	22.025	AE25	dark/12V	
Discaloy	22.030	AE30	dark/12V	
Gold & gold plate	22.010	AE10	dark/12V	
	22.021	AE21	dark/12V	
Hastelloy	22.037	AE37	dark/12V	
Haynes 25	22.001	AE1	dark/12V	
Inconel	22.037	AE37	dark/12V	
Inconel 718 & 750	22.030	AE30	dark/12V	
Iron	22.035	AE35	dark/12V	pH-neutral, low corrosion
	22.036	AE36	dark/12V	pH-neutral, low corrosion
Lead & alloys	22.030	AE30	dark/12V	
Monel	22.012	AE12	dark/12V	
	22.021	AE21	dark/12V	
Nickel & alloys	22.001	AE1	dark/12V	
	22.030	AE30	dark/12V	
Nickel plate (brass & copper)	22.021	AE21	dark/12V	
Nickel, chemical	22.003	AE3	dark/12V	
Nickel plate (steel & alu)	22.024	AE24	dark/12V	
	22.030	AE30	dark/12V	
Nickel silver	22.037	AE37	dark/12V	
	22.025	AE25	dark/12V	
Nitraloy	22.021	AE21	dark/12V	
Steels, stainless	22.001	AE1	dark/12V	
	22.024	AE24	dark/12V	
	22.035	AE35	dark/12V	pH-neutral, low corrosion
	22.036	AE36	dark/12V	pH-neutral, low corrosion
Steels, decorative (advertising material)	22.035	AE35	dark/12V	pH-neutral, low corrosion
	22.036	AE36	dark/12V	pH-neutral, low corrosion

Material, alloys, branch	ItemNo	Electrolyte	Power unit setting/ voltage	Notes
Steels, food & nutrition industry	22.007	AE7	dark/12V	pH-neutral, low corrosion
Steels, surgical instruments	22.033	AE33	dark/12V	pH-neutral, low corrosion
	22.034	AE34	dark/12V	
Steels, tool & high alloy	22.033	AE33	dark/12V	pH-neutral, low corrosion
	22.021	AE21	dark/12V	
Steels, hardened & unhardened	22.020	AE20	dark/12V	
Steels, corrosive	22.035	AE35	dark/12V	pH-neutral, low corrosion
	22.036	AE36	dark/12V	pH-neutral, low corrosion
Steels, until 1.4021 / 1.4310	22.001	AE1	dark/12V	
	22.033	AE33	dark/12V	pH-neutral, low corrosion
Steels, CrCo, steels from 1.4310	22.035	AE35	dark/12V	pH-neutral, low corrosion
Steels, low carbon	22.010	AE10	dark/12V	
	22.012	AE12	dark/12V	
Tin	22.010	AE10	dark/12V	
Titanium	22.037	AE37	dark/12V	Use minimum Electrolyte and short marking times (1-1,5s)
	22.028	AE28	dark/12V	
Tool steel	22.033	AE33	dark/12V	pH-neutral, low corrosion
	22.010	AE10	dark/12V	
Tool steel, high alloy & harden able	22.033	AE33	dark/12V	pH-neutral, low corrosion
	22.035	AE35	dark/12V	pH-neutral, low corrosion
Tungsten (pure)	22.028	AE28	dark/12V	Without neutralisation/cleaning
Tungsten carbide	22.026	AE26	dark/12V	Without neutralisation/cleaning
Zinc & zinc plate	22.010	AE10	dark/12V	
Zirconium	22.021	AE21	dark/12V	
	22.028	AE28	dark/12V	

L Ordering carbon stamps and stencils

Manual stamps and stamps

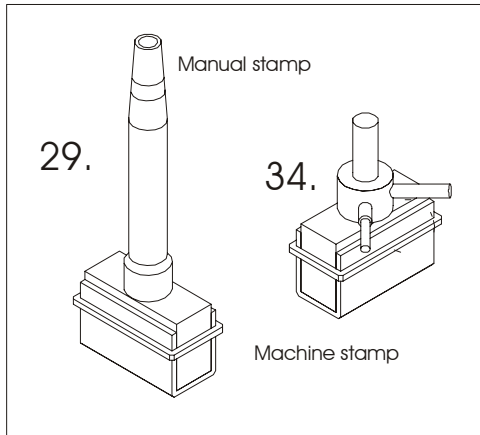

Select the manual stamp or machine stamp and note the first two numbers; these are the first two digits of the ordering number. Use the table provided below to determine the dimensions of the stamp; select a stamp shape from A to I and complete the ordering number. Please specify the desired diameter for stamp shapes B, C, E, F, G and H. Example: 34.806 C 8 = machine stamp/dimensions 50x15x25 mm/shape C/concave for 8 mm diameter.

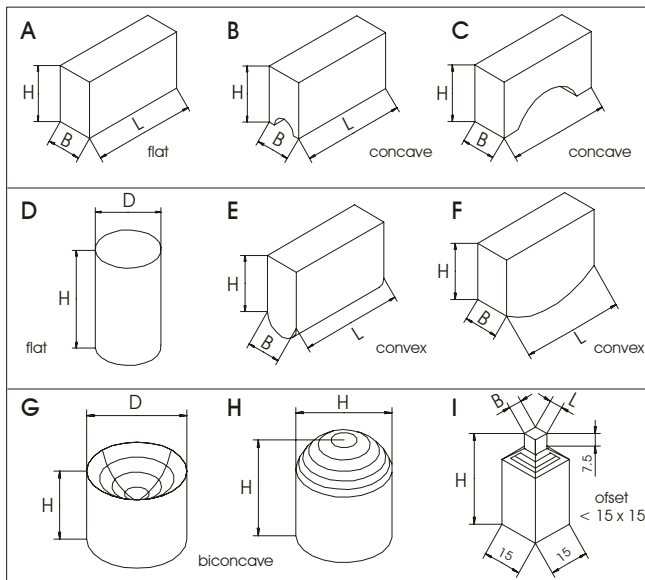

Standard dimensions Height 25mm Width 15mm

Ordering no.	Length in mm	Ordering no.	Length in mm
.800	15	.805	45
.801	20	.806	50
.811	25	.807	55
.802	30	.808	60
.803	35	.809	80
.804	40	.810	100

Other dimensions available on request. Manual stamp with integrated electrolyte supply, not pictured. Ordering no. 29.001
Automatic felt piece adjustment without stamp, not pictured. Ordering no. 11.130
Manual felt piece adjustment without stamp, not pictured. Ordering no. 11.120

Stencils:

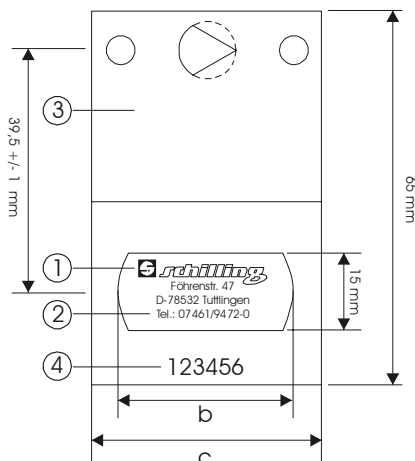

- ① Price for repros X €
- ② Price for photosetting, one line Y € (several lines available on request)
- ③ Price for marking stencil Z €
- ④ Price for subsequent orders Z €

Standard stencils

Ordering no.	a	b	Stamp size (dimensions in mm)
FO 40	40	30	≤ 30
FO 50	50	40	≤ 40
FO 60	60	50	≤ 50
FO 80	80	70	≤ 70
FO 100	100	90	≤ 90

Stencil with short service life

Ordering no.	Dimensions
22.160	BS 60x180mm
22.161	BL 60mm x 10m
22.162	BS 60mm x 25m
22.163	230 x 330mm
22.162.1	76mm x 30m perforated

Special stencils with special frames available on request

M Appendix

On the following pages of the revised Signomat S2000 Operating Instructions we have endeavoured to make your work as easy as possible. There is no need to read text any longer and the captions to the figures will allow you to learn how to operate the controller in a jiffy.

We wish you every success and a fast start!



Programming of controller
SIGNOMAT S2000
please refer to
separate manual

