

Megalight™

Marking Laser

General Manual

SCHILLING
Marking Systems GmbH



Schilling Marking Systems GmbH

In Grubenaecker 1
DE-78532 Tuttlingen Germany
Tel.: +49 (0)7461 9472-0
Fax.: +49 (0)7461 9472-28

www.schilling-marking.com
info@schilling-marking.com

Edition: 20.03.2004

Edition:	Subject areas covered in the new edition	No. of pages added or modified
20/03/2004		

Foreword

Megalight™ is a **Complex Component** not intended to be marketed as a single commercial unit but rather distributed exclusively as Original Equipment Manufacturer (OEM) to qualified Suppliers, Users, Installers who have the technical background in relation to the Safety requirements which an **Installed Laser System** must possess to become a **Laser Machine**, as defined by standard EN 12626 (ISO 11553).

The information contained in this manual is addressed to a qualified installer able to integrate the device in a system, completing all the protection systems required by international standards and local laws.

The following manual refers to the model Megalight™, in the two versions Marker and OEM, i.e. relative to a Laser source which has been designed and developed as a single component to be integrated in more complex systems to create a **Laser engraving system**.

The Manual has been written in compliance with the requirements of **EC directive 98/37** and subsequent modifications and integrations, and is intended to supply a qualified installer with instructions for:

- Conformity
- Shipping
- Use instructions
- Use contraindications
- Installation
- Commissioning
- Use
- Adjustments
- Maintenance
- Repair (if necessary)
- Training instructions
- Technical specifications
- Specifications of accessories
- Mechanical drawings
- Wiring diagrams

The functions required from creating an engraving system must be supplied by an **external Personal Computer**, with an appropriate **Engraving Software** installed on it.

The Marker version is supplied with an **Engraving Head** and **Smartist 4** engraving software with **DAC 2** Hardware (Board for PCI bus and D/A converter) needed for creating the engraving system. Installation and use instructions for **Smartist 4** are provided separately in a specific manual called: *Smartist 4 Manual*.

The OEM version does not include the Engraving Head, Hardware and Engraving Software.

It is advisable to carefully read the laser safety instructions contained in this manual and to refer to the separately provided *Laser safety guide*.

Make sure the system has not undergone damages from shipping when you receive it and before installing it. If there are any signs of possible damage, contact the shipping company to lodge a complaint and notify us at:



Schilling Marking Systems GmbH
In Grubenaecker 1
DE-78532 Tuttlingen - Germany
Tel.: +49 (0)7461 9472-0
Fax: +49 (0)7461 9472-28
eMail: volker.bartsch@schilling-marking.com

The information contained in this document is subject to modification and review without prior notification. All the names of the products referred to are registered trademarks belonging to the companies that created them. Reference is made to them for editorial reasons only. Microsoft, MS, MS-DOS, Windows 98, Windows NT, Windows 2000, Windows XP, Visual Basic, PowerPoint, Microsoft Press, are registered trademarks or trademarks of Microsoft Corporation in the United States and in other countries. TrueType is a registered trademark of Apple Computer, Inc.

N.B.:

Schilling Marking Systems GmbH shall not be held liable for any damage or injury arising from incorrect installation of its product by unqualified personnel and for damage or injury resulting from on conforming use of the supplied equipment!

N.B.:

This product is intended to be incorporated in an O.E.M. laser system and requires additional functions to make it in compliance with the specifications set forth in 21CFR 1040 or-60825. Class IV product.



CONTENTS

Symbols related to equipment safety	pg. 6
Definitions	pg. 7
Main preliminary safety warnings	pg. 8
Shipping	pg. 9
Disposal	pg. 9
CHAPTER 1: DESCRIPTION OF THE EQUIPMENT	pg. 10
Intended Use	pg. 10
Use contraindications	pg. 10
Use warnings	pg. 10
Composition	pg. 11
Layout of the device	pg. 12
Rack	pg. 14
Description of the main electrical system components	pg. 18
Main switch	pg. 18
I/O board	pg. 18
Current driver board	pg. 18
Laser diode	pg. 18
Peltier cell	pg. 18
Aiming laser diode	pg. 19
Display	pg. 19
Laser resonator	pg. 19
Engraving scanner head	pg. 20
Objective lens	pg. 21
CHAPTER 2: INSTALLATION and START-UP	pg. 22
Preliminary installation notes	pg. 22
Installation procedure	pg. 23
Environmental requirements	pg. 23
1. Connection to the mains	pg. 23
2. Connections	pg. 24
DSP board installation	pg. 24
Connectors'	pg. 25
Electrical connections	pg. 26
Optical Fibre Connection	pg. 27
Preliminary commissioning (Safety instructions)	pg. 30
Commissioning	pg. 30
Start-up procedure (Hardware)	pg. 30
Start-up procedure (Software)	pg. 31
Shutting Down	pg. 32
CHAPTER 3: USE and MAINTENANCE	pg. 33
General use instructions for Class IV lasers	pg. 33
Individual Protection Devices (IPD)	pg. 34
Daily use by an Operator	pg. 34
Turning on	pg. 34
Turning off	pg. 35
Replacing the lens	pg. 35
Ordinary maintenance	pg. 36
Technical modifications reserved	4
	Edition 2004

Cleaning the lens protection glass	pg. 36
Extraordinary maintenance	pg. 37

TROUBLESHOOTING

 pg. 39

APPENDIX A: TECHNICAL SPECIFICATIONS

 pg. 41

System Specifications	pg. 41
Identification	pg. 41
Conformity	pg. 41
Laser Source Classification	pg. 41
Equipment electrical specifications	pg. 42
Environmental and installation specifications	pg. 42
Laser Source Specifications	pg. 42
Mechanical specifications	pg. 43
O.E.M. device standard equipment	pg. 43
Separately supplied parts	pg. 43
MARKER device standard equipment	pg. 43
Possible field of adjustment	pg. 44
Warning labels and their positioning	pg. 45
Detailed label description	pg. 49
Mechanical drawings	pg. 51

APPENDIX B: WIRING DIAGRAMS







 pg. 53

Description of signals on connectors	pg. 53
Command Box (CB) Connector	pg. 53
External Interlock Connector	pg. 54
Galvo Supply Connector	pg. 54
Slave Out Connector	pg. 54
P.C. Connector	pg. 55
Aiming Beam Connector	pg. 55
R.F. Connector	pg. 56
Wiring diagrams	pg. 56

APPENDIX C: Safety notes

 pg. 62

SYMBOLS RELATED TO DEVICE SAFETY

Symbol	Meaning
	INDICATION: this symbol indicates that in this position the device power switch is off
O	INDICATION: this symbol indicates that in this position the device power switch is on
	GENERIC WARNING: (caution, warning, danger): this symbol indicates that the instructions regarding important manoeuvres or maintenance operations need to be carefully read.
	ELECTRICITY WARNING: this symbol indicates the presence of associated dangerous voltage, or powerful enough to constitute an electrical risk. This symbol must appear on the finished machine as well, at the electrical risk area.
	LASER WARNING: this symbol indicates the danger of exposure to visible or invisible laser radiation. This symbol must appear on the finished machine as well, at the optical risk area.
	FIRE WARNING: this symbol indicates the danger of a fire when processing flammable materials. For this reason it is necessary to follow the instructions provided by the manufacturer when commissioning the machine.
CE	CONFORMITY: this symbol indicates that the device has been produced in conformity with European Community directives.
	READ THE WARNING: this symbol indicates that it is obligatory to read the important remarks in the manual before continuing
	TEMPERATURE WARNING: this symbol indicates the presence of high temperatures which may involve a risk of being burned

Definitions

Term	Definition
F_p	Symbol of impulse repetition frequency
Q	Symbol of energy of one impulse
P_m	Symbol of the average power of a series of impulses
Hz	Hertz, unit of measurement for frequency (1 Hz – 1 impulse/s)
J	Joule, unit of measurement for energy
W	Watt, unit of energy for power (1W = 1 joule/second)
mJ	millijoule = one thousandth of a joule
μJ	microJoule = a millionth of a joule
DO	Optical Density, the exponential to the power of 10 of optical radiation absorption for laser protection glasses
NOHD	Nominal ocular hazard distance
λ	Symbol for wavelength (λ in nm)
α	Symbol for the divergence of the laser beam (α in mrad)
V ac	Rsm value of the alternate voltage in Volts

Note for laser parameters

The energy related to a single laser impulse is measured in microJoules. The average power of a train of impulses is measured in Joules/second, or Watts. This average power (Watts) is equal to the energy per impulse (Joules) multiplied by the impulse repetition frequency (Hertz).

Main Preliminary Safety Warnings



Before continuing with the installation of the device carefully read the following important preliminary safety warnings.



WARNING:

The main laser radiation of MegaLight™ is in Class IV. The free beam produced by a Class IV laser source may represent a significant risk for the eyes and skin even from a great distance!

The device is intended for use by instructed and informed personnel strictly within an industrial plant!



N.B.:

Before continuing with installation of the device make sure you have suitable goggles for protection against scattered radiation. Even with goggles, it is possible to damage your vision by viewing direct laser radiation. Avoid viewing direct radiation!



WARNING:

Before continuing with installation make sure that the environment is suitable for the intended use. In particular make sure there are no openings (windows or other) towards the outside which can let dangerous radiation leak out!



WARNING:

Install the laser on a stationary support. Unforeseen risks may be caused if the device falls!



WARNING:

The intensity of this laser is sufficient to ignite flammable material. **Do not aim the laser beam at flammable material.**



WARNING:

The interaction of the laser beam with the material causes the formation of fumes and vapors, which may be harmful or toxic. It is advisable to **eliminate the fumes with a specific suction device** and only release them to the air after they are filtered.

Shipping

Megalight™ must be shipped in its original packing to prevent it from undergoing bumping and vibration. The packing has a device which is sensitive to excessive bumping which may damage the internal parts.



WARNING:

After shipping and before starting unpacking operations make sure the **Antishock Wave** label applied to detect any bumping during shipment, **is intact**, If not, return to the sender.



WARNING:

Before starting unpacking operations carefully read the instructions on attached to the packing regarding handling the device.



N.B.:

Keep the packing; it needs to be used if the device is reshipped.

In addition, avoid exposing the device to rain, cold, excessive heat and/or humidity. During shipping do not expose the device to environmental conditions other than those listed below for more than 24 hours:

- ambient temperatures from - 5°C to + 55°C;
- relative humidity of 100% without condensation.

Disposal

No part of the device, including electronic, mechanical and optical, requires special precautions for disposal.



CHAPTER 1:

DESCRIPTION OF THE EQUIPMENT

Megalight™ is a Nd:YAG/passively Q-switched laser with wavelength equal to 1064nm, maximum power equal to 6W (in continuous operation) and operating frequency equal to 25KHz, pumped by a laser diode at 808 nm and air-cooled. The pumped source is remote controlled in relation to the laser head (**Resonator**) and is situated inside the rack. Coupling between the pump diode and laser head is done via **Optical Fibre**.

Intended Use

The device is designed and built for the application of engraving of non-flammable metal and plastic materials. If the intended use of the source is changed, for example for applications other than material processing, collateral risks may arise associated with the interaction of laser radiation with the material.

Use contraindications

Do not subject **materials other** than those the device was designed for to Laser radiation. The laser possesses intensity sufficient for igniting flammable material, so **do not direct the laser beam on flammable material**. The interaction of the laser beam with the material causes the formation of fumes and vapours, which may be harmful or toxic. It is advisable to use **appropriate suction devices to eliminate fumes** and filter fumes before releasing them into the air.

Use warnings

Megalight™ is a **Laser device** able to emit class **2M visible radiation** (aiming red beam) and a Class IV **main invisible radiation** (laser beam).

Visible lasers which are not able to damage the eye for momentary viewing but may represent a danger if viewed through a magnifying glass belonging to the class 2M.

Class IV includes lasers which can produce risks, not only from direct or reflected radiation, but also from **scattered** radiation! The main radiation is included in **Class IV**. The free beam produced by these laser sources may represent a significant risk for the eyes even at a substantial distance!

The device is intended for use by trained and informed personnel only within an industrial plant!

The installer must put into effect all measures aimed at containing the radiation to make sure that it is terminated at the end of its useful path. In addition, the final User (Operator) must be informed of the risks from exposure to Laser radiation and must wear specific I.P.D. (individual protection devices) including goggles that protect against radiation and are certified as such.



Composition

The Megalight™ device in its basic “O.E.M.” version is composed of:

- A power supply Rack containing the pump laser diode
- A compact laser Resonator, designed to take up little room.
- A connection Optical fibre

The components required to create the “**Marker**” set-up can be supplied separately as an option:

- Engraving scanner head
- Interfacing electronic boards and engraving software (Windows-based)
- A Personal Computer with Monitor, keyboard and mouse.

All engraving operations can be managed with the *Smartist 4* software program. (the minimum Personal Computer requirements and Software operating instruction are provided in the *Smartist4 Manual*).

The pictures below show the composition of an engraving system and the Megalight™ with Miniscanner model

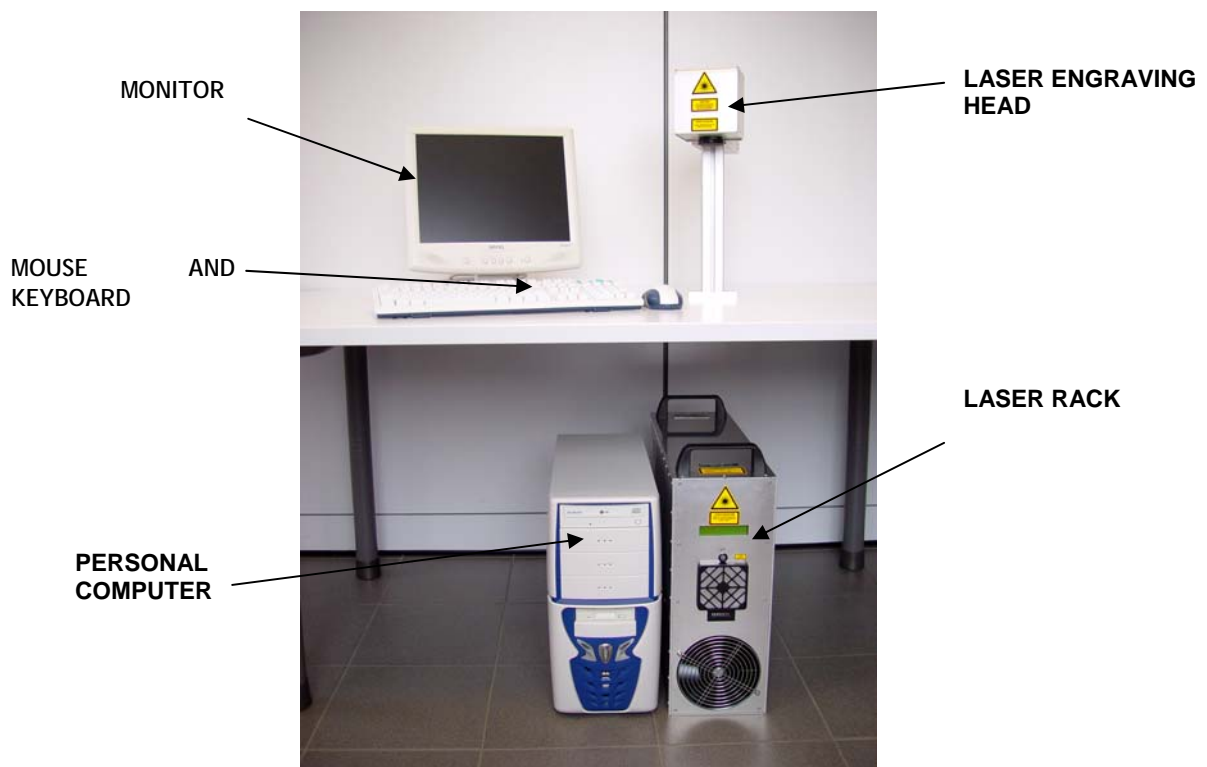

Picture 1: Megalight™ engraving laser system

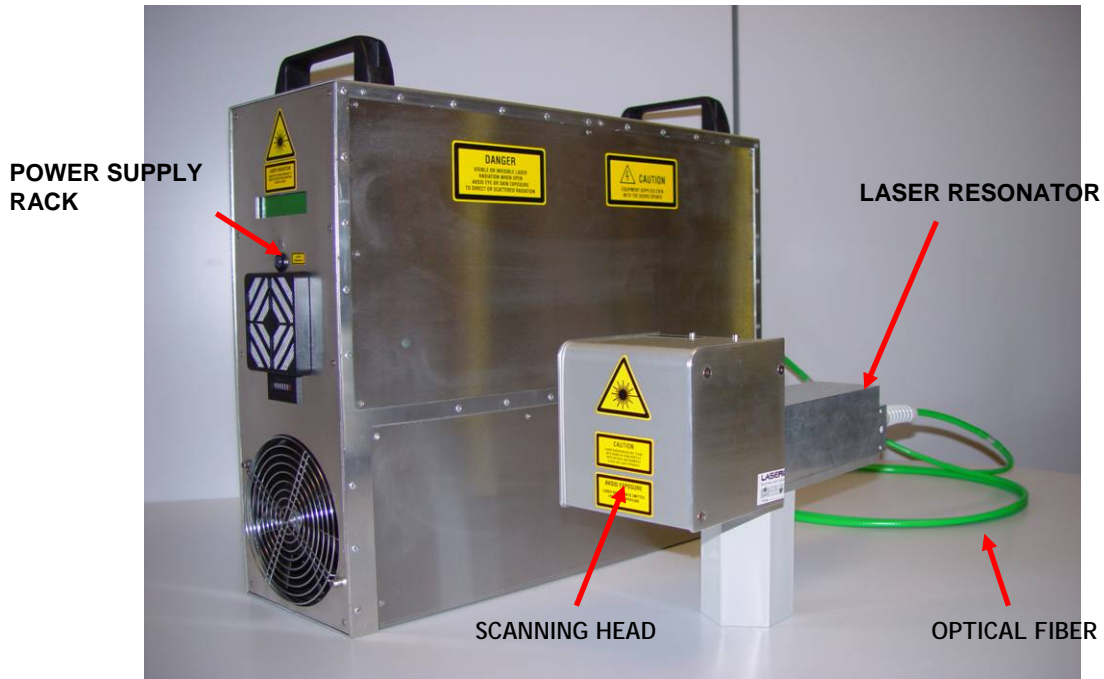

Picture 2: Laser MegaLight Layout

Device layout

The essential layout of the device highlights the main system components, composed of a **power supply rack** which generates Pump radiation at 808 nm, **optical fibre** which transports the pump radiation to the Resonator, **Resonator** which converts the 808 nm continuous radiation to pulsed radiation at 1064 nm, engraving **head scanner** which aims and deflects the laser beam on the engraving surface.

The following figure shows the system layout diagram.

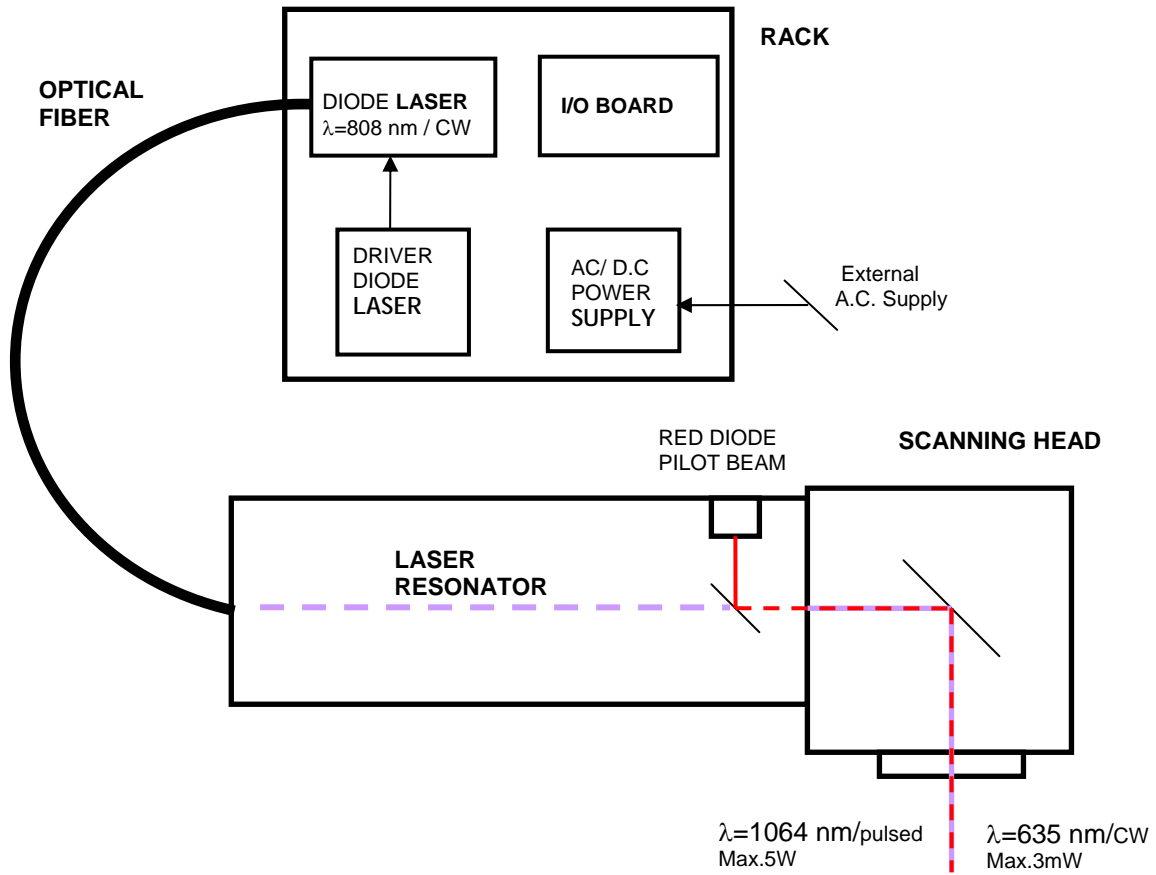

Picture 3: System layout of MegaLight™

Rack

The **power supply box** contains the following components:

- **AC/DC Power supplies** able to provide all the required service power supply
- **Coupler** for the pump laser diode with 808 nm wavelength.
- **Current driver** powering the laser diode.
- **Input/Output board.**
- **Radiators** for heat dissipation via forced ventilation completely separated from the electrical part.

The **front indicator panel** is aimed at the Operator of the MegaLight™ laser device and includes the following elements:

- Multilingual **display** for displaying alarm messages and indications
- **Three color LEDs** indicating the device operating status
 - POWER ON (green)
 - LASER IN STAND BY (orange)
 - LASER READY (red)
- **Hour meter** for recording the total activation time of the laser diode, making it possible to monitor the life of the laser diode and plan maintenance work ahead of time.
- **Fan** for circulating radiator cooling air



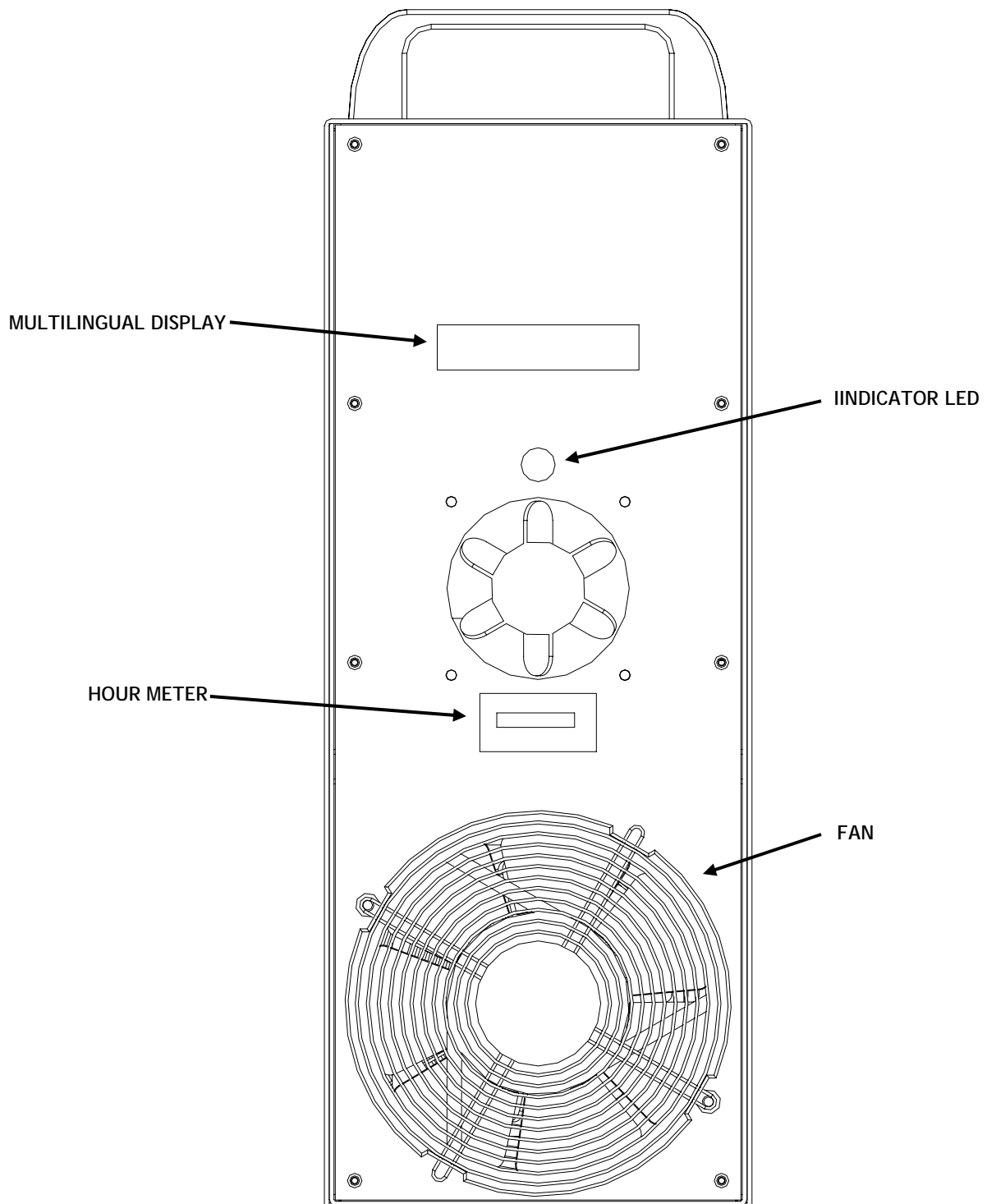

Picture 4: system rear panel: external indicators

The **rear management panel** faces the side opposite the operator and includes the following elements:

- 1 **Socket** for 230/110 Vac – 3/6A – 50/60Hz mains supply
- 2 **Main switch** to disconnect from the mains
- 3 **Protection fuses** (5x20mm, 6.3A/250V type T)
- 4 **Galvo Supply** connector (sub-D, 9 p., male) for Scanner Head power
- 5 **Internal Interlock** Connector (DIN, 3 p., male) for connection to an external emergency interlocks circuit.
- 6 **Aiming Beam** connector (SMB, female) for connecting the red aiming diode.
- 7 **Command Box** connector (sub-D, 25 p., female) for connection to an external command box.
- 8 **P.C.** connector (sub-D, 9 p., female) for connecting the device to the DSp2 contained in the external Personal Computer.
- 9 **Slave Out** connector (sub-D, 15 p., female) **(not used in this version)**.
- 10 **Optical Fibre** connector (D-80-LKA) for the optical fibre connection between the Rack and Resonator.
- 11 **R.F.** connector **(not used in this version)**.
- 12 **Cooling fan**



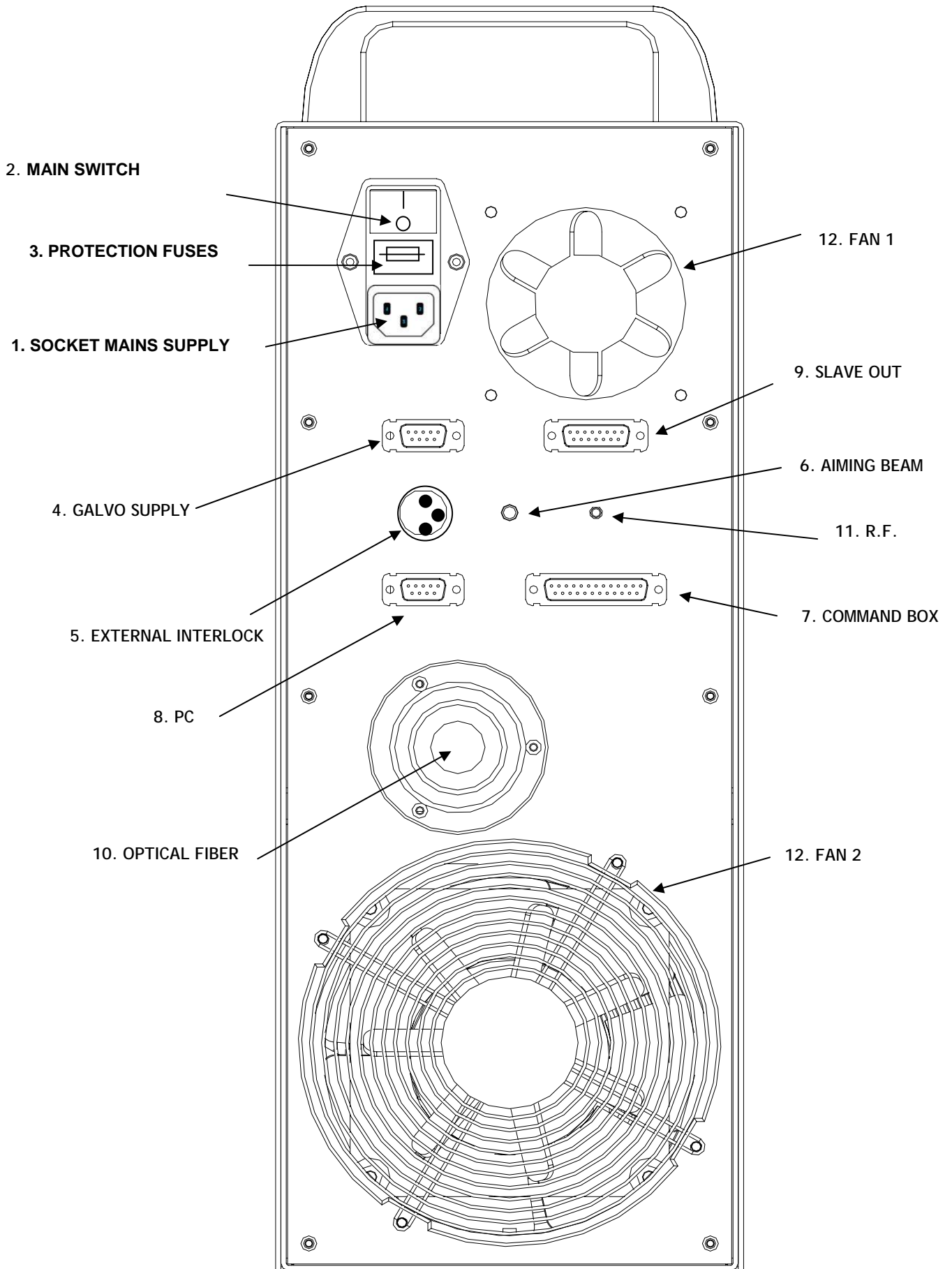

Picture 5: Rear management panel: external connectors

Description of the main electrical system components

Main switch

A line bipolar main switch (230/110Vac-10A) is contained in a filter with socket with double fuse holder. It is located on the rear Management Panel and carries out the following functions at the same time:

- Power disconnection device
- Protection device against overloading and short circuits (up to 1500 A)
- Category 0 emergency device.

The main switch is normally used in turn on and turn off operations.

Input/Output board

The input/output Board IOB communicates with the various elements of the electrical system, centralizing and sorting operational and management functions. The board IOB receives voltage directly from main switch and interfaces with:

- the AC/DC service power supplies,
- the radio frequency driver board (RFD), providing the 15Vdc low voltage and the command signals for driving the Q-switch (**not used in this version**)
- the current driver board
- the display
- the three color LED
- the hour meter
- the rear panel
- the fans
- the Peltier cells

In addition the **IOB** board communicates with the **DSP2** laser management board and creates the interface towards the outside.

Current driver board

The current driver board manages and controls the current which supplies the laser diode in a closed circuit.

Laser diode

The power laser diode **LD** is contained in the Coupler. It is powered at low voltage (2-4 Vdc) and medium-high current (up to 50A). Its operating temperature is detected by a temperature sensor and adjusted so that it stays between 20°C and 30°C. The Laser Diode provides the pump radiation at a 808nm wavelength, transported in Optical Fibre and necessary to supply the Resonator (optical pumping).

Peltier cell

The Peltier cell is placed in direct contact with the base of the Coupler unit and is located exactly below the power laser diode. It is supplied with 24Vdc voltage and transfers the generated heat from the laser diode to be eliminated by the Dissipater.

Aiming laser diode

The aiming diode laser with 635nm wavelength (visible in red) is supplied at low voltage (2.5-4Vdc) and is located in the Resonator unit. This visible radiation overlaps with the power laser beam and makes it possible to indirectly view the optical path, as well as the operating field at the output of the scanner head.

Display

Display provides the Operator with information on the status of the laser and is the first diagnostic tool in the event of a fault

Laser resonator

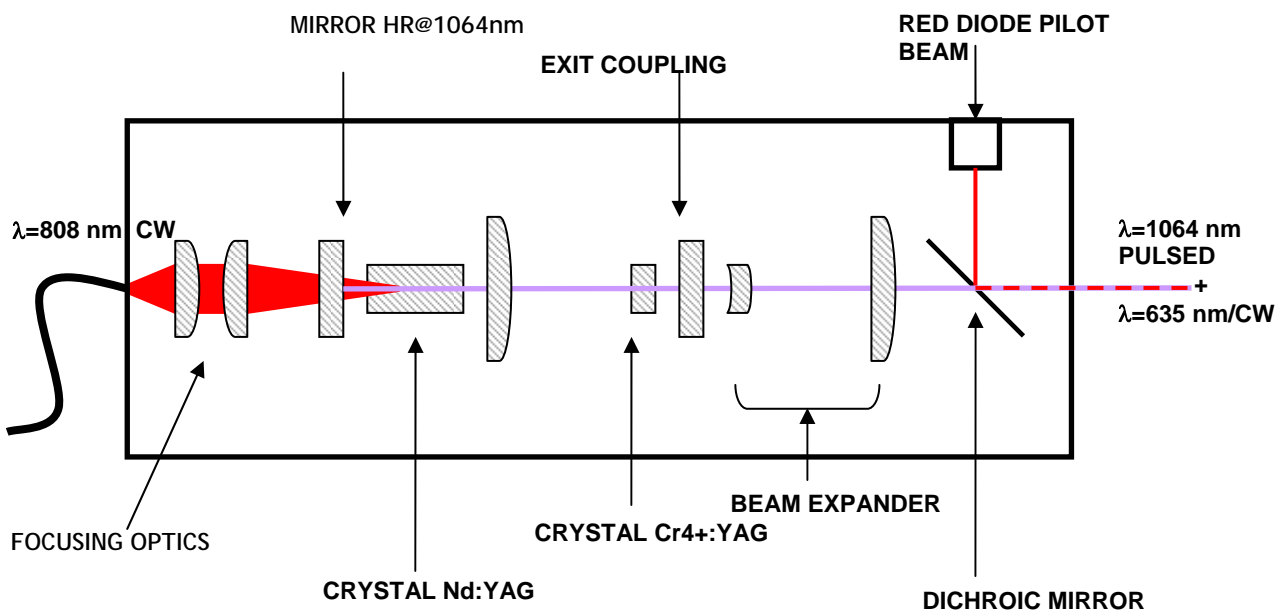

Picture 6: Laser Resonator

The laser **Resonator** is basically composed of a pair of lenses able to gather the radiation pumped at 808nm output from the optical fibre and focalized inside the crystal of active material (Nd:YAG) by a pair of aligned mirrors which act as an oscillator for the laser radiation at 1064nm and a Cr4+:YAG, which acts as a passive Q-switch and is used to generate instantaneous high power laser impulses suitable for engraving. The final stage carried out a beam-expander function: it increases the diameter of the output laser beam and improves the collimation in order to be able to improve the focalization of the beam in a spot of reduced dimensions, to obtain elevated irradiation on the engraving plane.

The aiming red diode is also situated in the Resonator unit, returned by a dichroic mirror so that it overlaps the laser beam exactly and can be used to learn the main path of the invisible radiation, even if indirectly. The architecture of the laser head created in this manner is used to obtain an output laser beam of a very high modal quality, with high performance and very little heat to dissipate.

The **connection for the optical fibre** is located in the rear wall of the Resonator (see *Appendix A: Technical Specifications*):

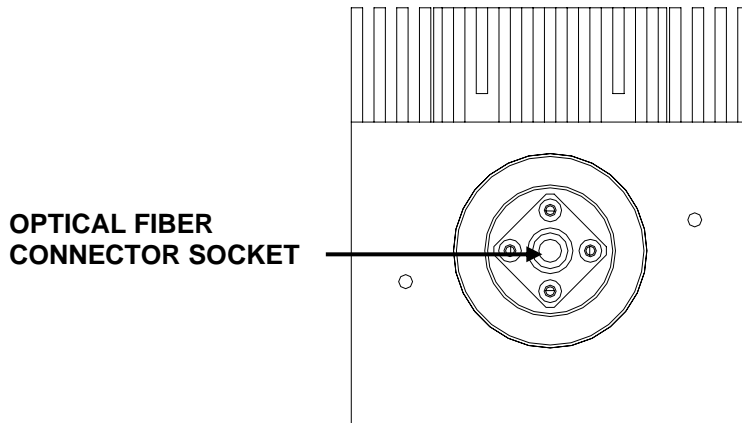

Engraving scanner head

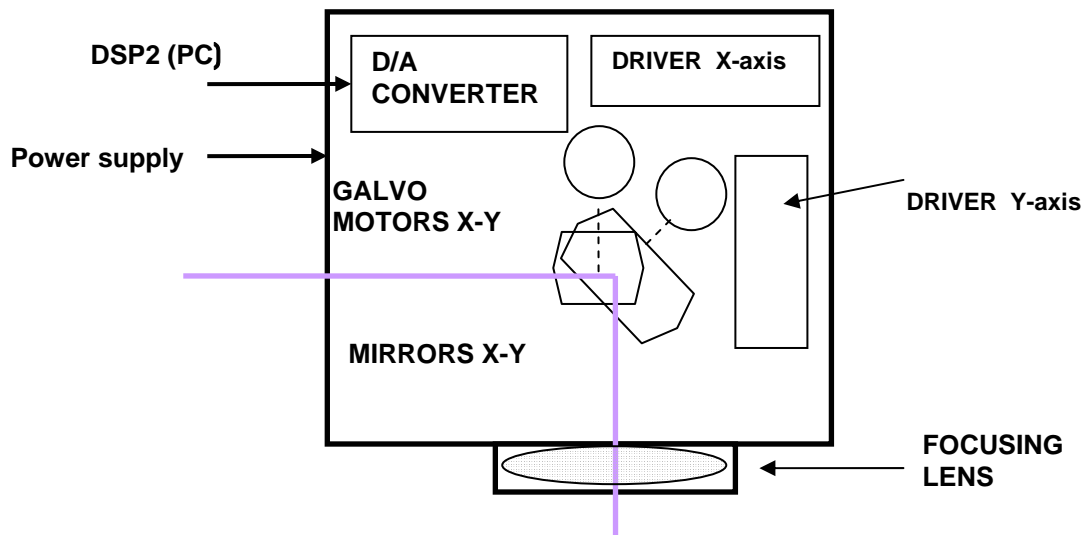

Picture 7: Galvanometric scanning head to direct the laser beam

Two tilt able mirrors are installed inside the engraving scanner head, moved by galvo-motors and run by the DSP2 board installed in the P.C., which in turn interfaces with a digital analogy converter **D/A**, also installed in the head.

Two connectors are present outside of the Miniscanner type head (see *Appendix A: Technical Specifications*):

- Scanner head **power supply** connector (connector DB9)
- **Galvo-motor** command connector (connector DB25)

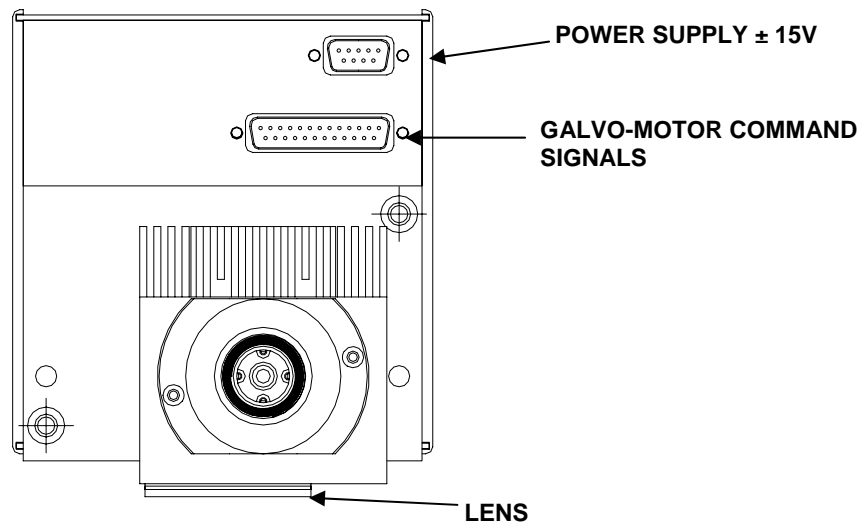

Picture 8: Rear view of the Engraving Head with connectors

Objective lens

The objective lens can be fitted with different length lens. Typically, for the Miniscanner head:

Lens length (mm)	63	100 *	160
Work area (mm x mm)	35 x 35	60 x 60*	100 x 100
Work distance (mm) ¹	73 ± 2	97 ± 2*	180±5

* available in the near future
¹ from lens edge

For Scanlab head:

Lens length (mm)	100	160	254
Work area (mm x mm)	50 x 50	110 x 110	180 x 180
Work distance (mm) ¹	98 ± 2	175 ± 5	285 ± 5

CHAPTER 2:

INSTALLATION and START-UP

Preliminary installation notes

This chapter discusses the subjects related to the installation procedure for the MEGALIGHT™ device and the tests to safely start it.

Installation must be effected by TRAINED AND QUALIFIED personnel because it involves effecting electrical and optical tests which require a specific qualification.

Warning: before installing the device carefully read *Appendix C, Safety Notes*, related to the main standards regarding Class I laser devices containing Class IV sources.

WARNING:



The mains voltage is dangerous. **If adequate precautions are not taken it can cause electric shock!** To avoid the electrical risk do not use connection wires, plugs, sockets or extension cords lacking a quality mark or which are not intact.

N.B.:



Before continuing with installation the device makes sure you have suitable goggles available for protection against scattered laser radiation. Even with goggles, it is possible to damage your vision by viewing direct laser radiation!

WARNING:



Before continuing with installation make sure that the environment is suitable for the intended use. In particular make sure there are no openings (windows or other) towards the outside which can let dangerous radiation leak out!

WARNING:



Install the laser on a stationary support. Unforeseen risks may be caused if the device falls!

WARNING:



Only use original wires, connectors and optical fibres. Wires with an incorrect dimension of loose connections can cause an electrical shock or a fire.

WARNING:



Do not bend the optical fibre beyond the minimum radius indicated. Greatly bending the fibre may cause unforeseen optical risk.

Installation procedure

Environmental requirements

Before installing the MegaLight™ engraving system, make sure that:

- The system is situated in a controlled area dedicated to laser processing.
- Until the system has been installed with all the safety devices and until its correct operation has been tested, the installer must have the laser area guarded and not let unauthorized personnel access the area.
- The System is positioned on a stationary surface with no vibration. In order to prevent distortions in the engraving, install the head and the piece to be worked on the same support, so that the piece is not subject to vibration during processing.
- To adequately house the wires and standard optical fibre equipped with the System (max. length 3m), the power supply box and laser head must be positioned at less than 2m. Longer wires and optical fibre can be supplied upon specific request.
- Leave a free space of at least 10 cm in front of and behind the power supply box to ensure the necessary flow of cooling air.
- **Do not** install the System in an excessively dirty area, in the presence of dust, oil, chemicals, fumes or excessive humidity.
- **Do not** install the system in a place where the ambient temperature falls below 15 °C or can rise above 35°C.
- **Do not** install the System in a place where the relative humidity often exceeds 80%.
- **Do not** install the System in a place with an altitude over 1500m.

(see *Appendix A: Technical specifications*)

N.B.: Sudden and often variations in temperature can cause condensation on the surfaces of the lens with the deposit of dust, which can damage optical parts.

1. Connection to the mains

The required mains is the Public mains protected and dimensioned with the following requirements:

- Single phase voltage P+N+PE 90-240Vac ($\pm 10\%$)
- Mains frequency 50-60Hz
- Harmonic distortion < 10%
- Interruptions < 3ms
- Max absorbed power 400W



WARNING:

Do not work on the electrical part if you are not an expert!

Do not remove protection devices.

Do not replace the fuses with ones of another calibre and type.

The wall socket for connection must be protected by a switch with 16A fuses able with their high interruption power (normally 6000A) to interrupt the short circuit current of the mains.

**N.B.:**

The fuses inside the MEGALIGHT™ device are not able to directly interrupt the short circuit current. **If not adequately interrupted the short circuit current may cause a fire!**

2. Connections

The following procedure refers to the device in its "MARKER" set-up.

When they arrive the Resonator and Engraving Head are already connected together and separately packaged from the Rack and Optical fibre. The necessary wires, interface DSP2 board to be installed in the PC, *Smartist4* engraving software and related manual are also in the packaging.

The System installation procedure involves the following phases:

- Preparation of the Personal Computer (P.C.) and installation of the DSP2 board,
- Mechanical attachment of the laser head. See *Appendix A. Technical specifications* for the points for attaching the laser head.
- Electrical system connections
- Optical fibre connection.

DSP board installation

The complete engraving laser system includes the following components:

- DSP board, to be connected to a standard or industrial PC PCI type slot.
- DSP board driver (available for Windows 95 / 98 / 98Me / NT4 / 2000 / XP).
- DSP Control program for tuning engraving parameters
- Graphic editor for creating engraving models.



The hierarchy of the components is illustrated in the following figure:

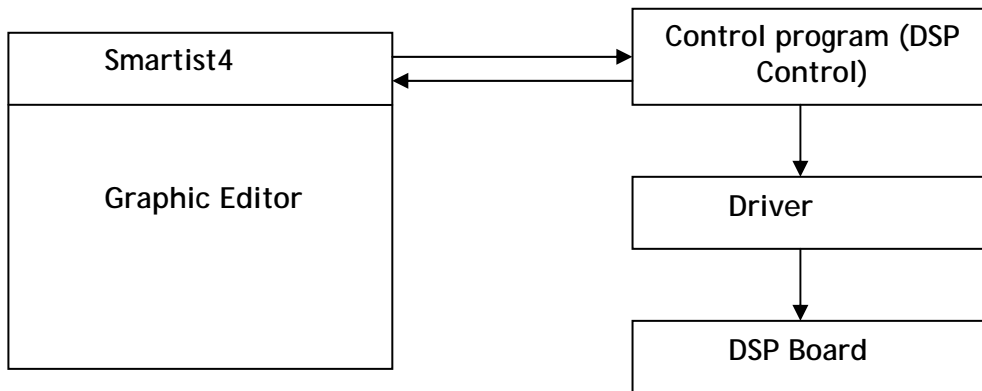

Picture 9: Software management diagram

For the complete installation procedure of the DSP board and *Smartist4* software see the related dedicated manuals (*Smartist4 instruction and installation manual*)

Connectors

The system is equipped with the wires and connectors described below:

- **DL:** plug-plug wire (length 3m) connecting the AIMING BEAM connector of the rear Management Panel of the power supply box and the SMB socket located on the laser resonator body.
- **TS:** SUB D 9 Female socket-socket wire (length 3m) connecting the GALVO SUPPLY connector of the rear Management Panel of the power supply box and the SUB D 9 pin Male connector located on the scanner head.
- **STS:** SUB D 25 pin Male plug-plug wire (length 3m) connecting the 25 pole Female SUB-D connector of the DSP board and the SUB D 25 pin Female connector located on the scanner head.
- **PC:** SUB D 9 Male plug-plug wire (length 3m) connecting the PC connector of the rear Management Panel of the power supply box and the DB 9 pin Female connector of the DSP board.
- Mains socket/plug wire.

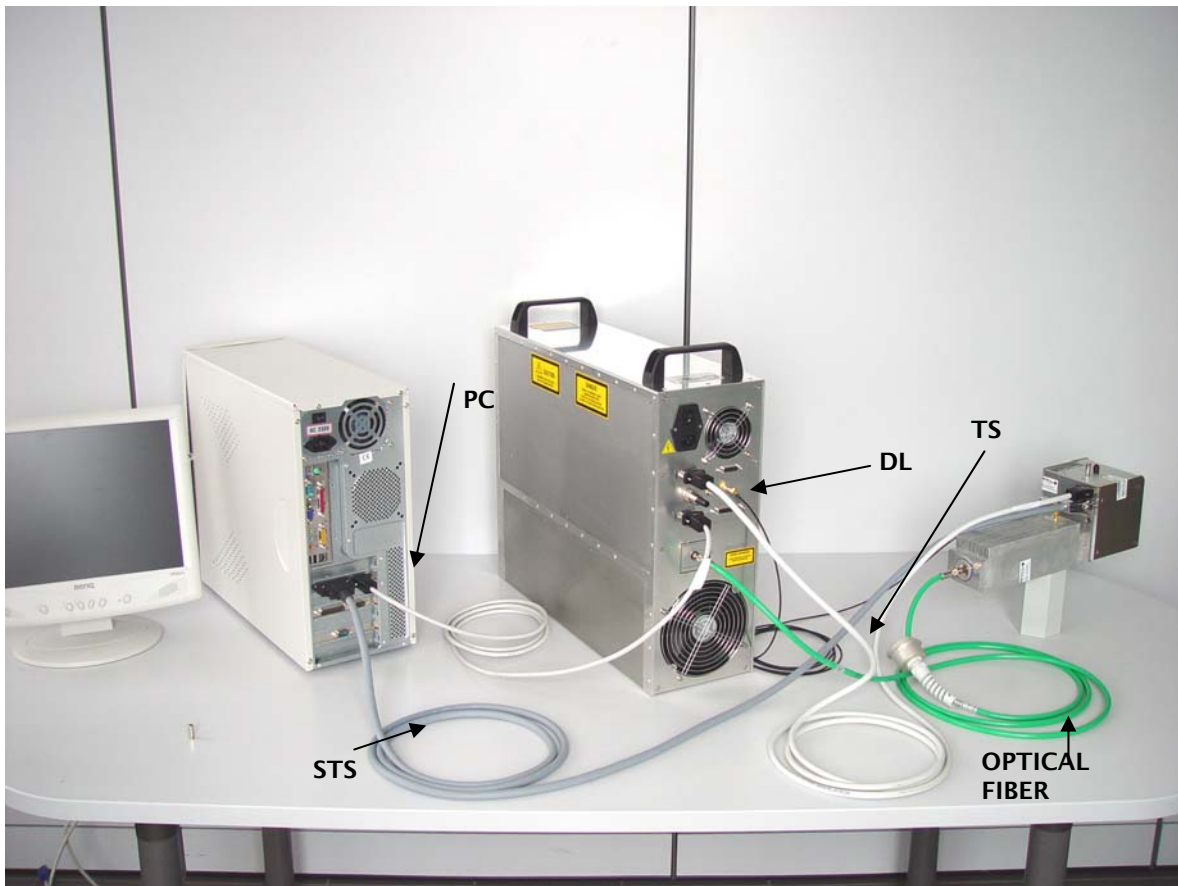

Picture 10: Layout of connection wires

Electrical connections

The sequence of the electrical connections involves the following phases:

- Make sure the main switch MS is in the OFF position. (**○**)
- Connect the DL wire between the AIMING BEAM connector (6) of the rear Management Panel of the power supply box and the SMB socket located on the laser head body.
- Connect the TS cable between the GALVO SUPPLY connector (4) of the rear Management Panel of the power supply box and the SUB D 9 pin M connector on the scanner head.
- Connect the STS wire between the SUB-D 25 pole F connector of the DSP board and SUB-D 25 pin F connector located on the Scanner Head;
- Connect the PC wire between the PC connector (8) of the rear Management Panel of the power supply box and the DB 9 pin F connector on the DSP board.
- Connect the power supply wire (1) of the rear Management Panel.
- Connect the monitor, mouse and keyboard to the related connectors on the PC.

N.B.: the connectors (11) RF and (9) SLAVE OUT are not used in the Megalight™ engraving system.

N.B.: It is possible to connect all the devices aimed at making the laser source safe in series with EXTERNAL INTERLOCK connector (5).

For detailed wiring and connection diagrams, see *Appendix B. Wiring and connection diagrams.*

Optical fiber connection.

The optical fibre is connected between the laser opening of the power supply box (connector 10: OPTICAL FIBER) and the optical fibre connector socket on the rear wall of the Resonator.

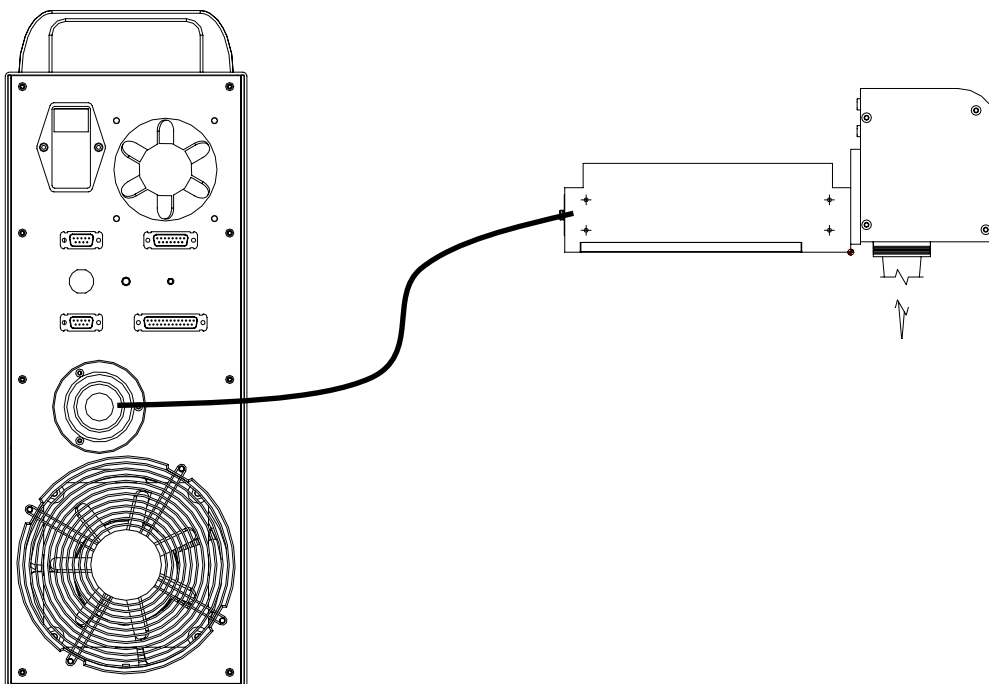

Picture 11: Optical Fibre Connection

The **procedure to connect** the optical fibre to the **rack** is as follows:

1. Make sure the main switch MS is in the OFF position (O).



WARNING:

Laser radiation may leak from the OPTICAL FIBER connector (10) of the power supply box. Never work with the device power on. Working with the device power on may cause serious optical risk.

2. Slide the optical fibre into the spring mounted grommet in the supplied back cover.
3. On the Rear Management Panel of the power supply box, remove the protective sticker and seal on the OPTICAL FIBER connector (10).
4. Referring to *Fig. 12: optical fibre connector*, remove the protective cap (1) from the optical fibre connector, by unscrewing nut (4).
5. Insert the optical fibre connector in the OPTICAL FIBER connector (10) of the power supply box:
 - gently place the optical fibre connector on the fibre socket
 - carefully insert the optical fibre connector, making absolutely certain that the optical surface of the fibre connector (2) does not come into contact with any other surface.

**WARNING:**

The operation for inserting the fibre needs to be carried out very carefully. Absolutely avoid letting the optical surface of the fibre connector come into contact with any other surface.

Contact of the fibre optical surface with any other surface may damage it.

6. Make sure the mechanical supports (3) on the male/female connectors are in the correct position.
7. Screw down nut (4) in the OPTICAL FIBER connector of the power supply box.
8. Screw down the rear cover on the power supply box.

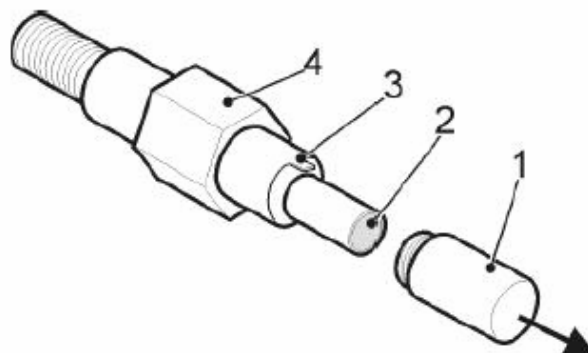

Picture 12: Optical fiber connector

The **procedure to connect** the optical fibre to the **Resonator** is as follows:

1. Make sure the main switch MS is in the OFF position (O).

**WARNING:**

Laser radiation may leak from the free end of the optical fibre. Never work on the device with the power on.

Operating with the rack power on may cause serious optical risk.

2. Remove the rear cove of the resonator, by unscrewing the three screws (see *Appendix A. Technical specifications*).



3. Slide the optical fibre into the spring mounted grommet in the back cover.
4. Remove the protection cap from the fibre socket located on the rear wall of the Resonator.
5. Referring to *Fig. 12: Optical fibre connector*, remove the protective cap (1) of the optical fibre connector, by unscrewing nut (4).
6. Insert the optical fibre connector in the fibre socket present on the rear wall of the Resonator:
 - gently place the optical fibre connector on the fibre socket
 - carefully insert the optical fibre connector, making absolutely certain that the optical surface of the fibre connector (2) does not come into contact with any other surface.

WARNING:

The operation for inserting the fibre needs to be carried out very carefully. Absolutely avoid letting the optical surface of the fibre connector come into contact with any other surface.

Contact of the fibre optical surface with any other surface may damage it.

7. Make sure the mechanical supports (3) on the male/female connectors are in the correct position.
8. Screw down nut (4) on the Resonator fibre socket connector.
9. Screw down the rear cover on the Resonator again.

N.B.:

Keep the protection caps for the optical fibre and fibre socket. Returns of optical fibres or resonators without these caps will not be accepted.

WARNING:

The optical fibre must never be subject to curve radii under 15 cm. to prevent damaging it or breaking it.

WARNING:

The optical fibre is an integral part of the laser engraving system.

Do not work with the optical fibre disconnected or damaged.

Using an optical fibre which is greatly bent, damaged or poorly connected may lead to a serious optical risk.

Preliminary Commissioning (Safety instructions)

**WARNING:**

When commissioning and before the laser radiation protection barriers have been positioned, always wear goggles with an optical density OD of 5 or higher, which are certified as in conformity with both wavelengths of 808nm and 1064nm. *Always* avoid direct viewing of the laser beam. No goggles are able to withstand direct laser radiation for long.

**WARNING:**

The installation, use or maintenance of the system in a manner other than that described in this manual may cause dangerous exposure to laser radiation or electrical risk.

Commissioning

Before starting the start-up procedure make sure the following preliminary operations have been carried out:

- Make sure the operating area is free from clutter.
- Make sure there is enough free space in front of and behind the power supply box, to ensure cooling air flow.
- Make sure that the plug is correctly inserted.
- Make sure all the electrical connection have been correctly effected.
- Make sure the optical fibre is connected to the power supply box and Resonator.
- Make sure the protective cover of the scanner head lens has been removed.
- Make sure the optical path of the laser beam terminates at the end of its useful path.

Start-up procedure (Hardware)

1. Put the main switch MS in the closed position (I) and make sure the following events occur at the same time:
 - the display goes on
 - the fans start
2. Give the START command, using an impulse command to close the contact between pin 04 and 12 of the COMMAND BOX connector (7) located on the rear Management Panel of the power supply box (see *Appendix B. Wiring and connection diagrams*). Make sure that the following event occurs:
 - GREEN led on POWER ON condition
3. After around 1 second, if the laser diode temperature is correct, the device is ready to operate and goes to the Stand-by condition. Make sure that the following events occur:
 - ORANGE led on: STANDBY condition
 - The aiming red diode appears at the output of the laser beam

4. Enable the ELECTRONIC SHUTTER, closing the contact between pin 07 and 08 of the COMMAND BOX connector (7) located on the rear Management Panel of the power supply box (see *Appendix B. Wiring and connection diagrams*).
Make sure that the following events occur:
 - RED led on: READY condition
 - The aiming red diode disappears from the beam
5. Disable the ELECTRONIC SHUTTER, reopening the contact between pin 07 and 08 of the COMMAND BOX connector (7) located on the rear Management Panel of the power supply box (see *Appendix B. Wiring and connection diagrams*).
Make sure that the following events occur:
 - ORANGE led on: return to STANDBY condition
 - The aiming red diode reappears at the beam

N.B.: once this hardware start-up phase is finished, the laser source is in the condition to accept the ENABLE command and pass from STANDBY to READY and ready to operate.

Start-up procedure (Software)

1. Start the Personal Computer where the DSP2 board has been installed on the P.C.I. Bus following the instructions in the *Smartist4 Manual*.
2. Install the *Smartist4* engraving software.
3. Follow the instructions for starting the software and engraving contained in the *Smartist4 Manual*.
4. Carry out the start-up procedure to bring the device to READY condition.



WARNING:

From this point on the source is ready to emit laser radiation for the Resonator or engraving head, if connected.

5. Select an engraving file and then give the START ENGRAVING command.
6. Effect a few engravings to make sure the device is operating correctly.



Shutting Down

1. Disable the ELECTRONIC SHUTTER, opening the contact between pin 07 and 08 of the COMMAND BOX connector (7) located on the rear Management Panel of the power supply box (see *Appendix B. Wiring and connection diagrams*).
2. Give the STOP command, opening the contact between pin 04 and 12 of the COMMAND BOX connector (7) located on the rear Management Panel of the power supply box (see *Appendix B. Wiring and connection diagrams*).
3. Exit the *Smartist4* engraving program.
4. Put the main switch MS in the open position (**○**) .



CHAPTER 3:

USE and MAINTENANCE

In order to use the device on a daily basis, the **Installer** must take care of installing all the **Safety devices** consists of casings or protection barriers suitable for preventing access to the laser device and/or the work area and preventing leakage of dangerous laser radiation. The use of suitable protection devices is able to reduce the acceptable emission limit (AEL) of the dangerous Class IV laser source, to the level of a Class I source, considered not dangerous. The casings or protection barriers must be sufficient for intercepting the emitted laser radiation from the source and resistant to perforation.

For the Megalight™ engraving system and for medium-low power laser, a metallic protection of a 1 mm thickness is able to completely and indefinitely shield non-focalized laser radiation. If it is necessary to access the device inside the casing by removing part of the casing, it is necessary to use safety blocks, which reduce the laser radiation to non-dangerous levels when they are activated. This can be created by electric interlocks, which must be in conformance and tested as a safety device.

Any inspection or observation windows must have built-in Optical Density filters able to lower the AEL to Class I. The filters must be in conformance and tested as a safety device.

General use instructions for Class IV lasers

The use of remote controls is also envisaged for Class IV lasers as well as starting with a key command, existence of an emission warning, availability of an attenuation/shutter command, positioning of controls outside the radiation access area and clearly visible appropriate warning labels.

The manufacturer of Megalight™, makes the possibility of complying with these regulations available to the Installer. Nevertheless, it is the Installer's responsibility to integrate all the necessary safety devices in the laser system.

The external safety devices include:

- Connecting an interlocking contact to the remote locking connector (**External Interlock**) which blocks laser emission and prevents it from restarting if it is open.
- Connecting an emergency laser contact to the connector (**Command Box**) which blocks laser emission and only allows restarting after an intentional manoeuvre if it is open.
- Equipping the system with a key start command connected to the connector (**Command Box**) which can be removed in the OFF position to prevent unauthorized personnel from using the laser system.
- Connecting an external device for enabling/disabling the shutter to the connector (**Command Box**), aimed at temporarily blocking laser emission.
- If the three color led on the rear panel of the rack is not directly visible, connect an external device which signals laser radiation emission in progress, for example a flashing red light, to the connector (**Command Box**).
- Position the Operator commands in an ergonomic position outside of the optical risk area.
- Repeat the warning labels on all removable panels, which when removed, allow access to the optical risk area.



Individual Protection Devices (I.P.D.)

Before using the laser system, the **Operator** must be instructed on the risks involved with using the laser system and the necessity of wearing protective goggles during all operations which require accessing the radiation.

The Nominal Ocular Hazard Distance (NOHD) for the Megalight™ is equal to approximately 15m in the case of direct or reflected radiation and 0.5m in the case of scattered radiation.

Warning: the goggles are not sufficient for protecting the eye from direct laser radiation.

Before using the laser system, the **Operator** must be instructed on the risks associated with using the device primarily resulting from the possibility of igniting flammable material, when hit by laser radiation, such as volatile substances, resins or plastics.

The interaction of the laser beam with organic or inorganic compounds causes the formation of fumes and vapours, which may be harmful or toxic.

N.B.: Make sure the personnel assigned to using the System have read this manual and the Laser Safety Manual before using the engraving system.

Daily use by an Operator

The **Operator** is required to carry out the following preliminary tests before each use of the laser device:

- Make sure the operating area is free from clutter.
- Make sure there is enough free space in front of and behind the power supply box, to ensure cooling air flow.
- Make sure that the plug is correctly inserted.
- Make sure all the electrical connection have been correctly positioned.
- Make sure the optical fibre is correctly connected to the power supply box and Resonator.
- Make sure the protective cover of the lens, located on the engraving head, has been removed.

Turning on

The Operator must carry out the procedure described below to turn on the system:

1. Put the main switch MS on the CLOSED position (**I**)
2. Start the P.C.
3. Start the *Smartist4* engraving software (see the specific manual).
4. If necessary, wear the specific individual protection devices
5. Start the device by giving the START command and making sure the following events occur:



- ORANGE led on: STAND-BY condition
 - The aiming red diode appears on the beam
6. Enable the ELECTRONIC SHUTTER using the STAND-BY / READY button and make sure the following events occur:
 - RED led on: READY condition
 - The aiming red diode disappears from the beam
 7. If this occurs, temporarily remove the protections to access the work area.
 8. Adjust the focus of the laser and engraving parameters, following the instructions in the *Smartist4 Manual*.
 9. Restore the protections, if they were removed earlier.
 10. Start engraving.

**WARNING:**

From this time on the source is enabled for emitting laser radiation from the engraving head. Be careful not to expose yourself to optical risk.

Turning off

1. Disable the ELECTRONIC SHUTTER using the STAND-BY / READY button and make sure the following events occur:
 - ORANGE led on: STAND-BY condition
 - The aiming red diode appears on the beam
2. Give the STOP command and make sure the following events occur:
 - GREEN led on POWER ON condition
 - The aiming red diode disappears from the beam
3. Exit the *Smartist4* engraving program.
4. Put the main switch MS in the open position (**O**) .
5. Replace the protective cover on the lens, located on the engraving head.
6. Disconnect the device from the mains.

Replacing the lens

If it is necessary to replace the lens, proceed as follows:

1. Make sure the main switch MS is in the OFF position (**O**) .
2. Cap the lens with the specific lens supplied with the system.
3. Unscrew the lens from the engraving head and cap the upper surface as well.



4. Screw the new lens into the engraving head, after having removed the upper protection cap and cleaned the optical surface.

N.B.: Make sure the new lens is mechanically compatible with the engraving head seat. If the new lens is not compatible with the engraving head seat, create an adaptation flange.

Once the lens has been replaced, the laser focus needs to be adjusted again.

Ordinary maintenance

Ordinary maintenance performed by the Operator exclusively involves cleaning the protection glass of the lens and cleaning the area around the fans. These operations must be carried out on a weekly basis.

Cleaning the lens protection glass

- Turn off the System.



WARNING:

Disconnect the device from the mains before doing any maintenance work.

- Pour a few drops of acetone or ethyl ether on a rag.
- Gently rub the glass with a circular movement, from the centre towards the outside.

(See the following Picture).



WARNING:

Let any flammable solvents or cleaning fluids used to clean the lenses dry before the laser is put back into operation.



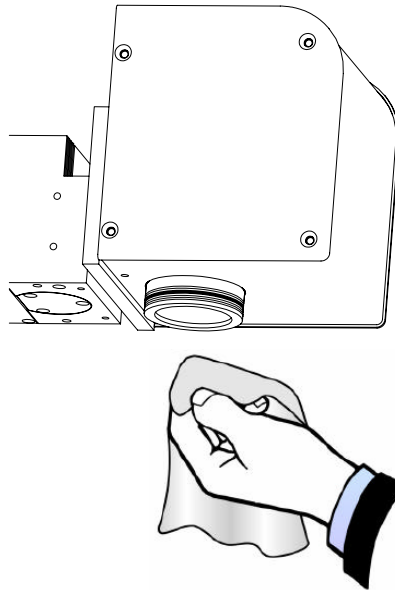

Picture 13 Cleaning of objective lens

The operator is not required to perform any other operations, except periodically checking the condition of the optical fibre. If the optical fibre breaks it is advisable to replace it with an original fibre supplied by the manufacturer to avoid a decrease in the degree of safety.

Extraordinary maintenance

**WARNING:**

The Operator is forbidden to carry out the extraordinary maintenance described below. These operations require specific training on the necessary maneuvers and safety measures to be adopted.

The Manufacturer's warranty shall be considered null and void following unauthorized work carried out by unqualified personnel on Manufacturer supplied parts.

If it is necessary to recalibrate the system or replace or do maintenance work on live internal parts, only use qualified personnel which is authorized by the Manufacturer or its legal representative.

For all Technical Assistance needs or extraordinary maintenance work it is possible to contact the Manufacturer's CALL CENTER at +49 (0)7461 9472-19, providing the following preliminary information:

- device model and serial number
- detailed description of the fault, evident damage or decrease in performance
- outcome of any tests performed
- name and phone number of the contact person

If the Manufacturer authorizes a return, the device or its parts are returned in the original packing. Following receipt of the returned part, the Manufacturer will determine the status of the warranty and communicate the estimate for the repair (if necessary) and the scheduled return date.



**WARNING:**

Serious electrical risk may result from accessing the internal parts of the electrical system. Only qualified and authorized personnel are allowed access to the internal parts of the electrical system.

Schilling Marking Systems GmbH shall not be held liable for work done on the live parts by unauthorized personnel.

**WARNING:**

Only qualified and authorized personnel are allowed access to the internal parts of the laser Resonator.

Schilling Marking Systems GmbH shall not be held liable for work done on the live parts by unauthorized personnel.

**WARNING:**

The operations described below involve intentional access to laser radiation.

Schilling Marking Systems GmbH shall not be held liable for work done on the live parts by unauthorized personnel.



TROUBLESHOOTING

The following information is aimed at permitting a first level of intervention in the event of a fault.

If the fault is different than those described below, or if the suggested remedy does not solve the problem, see the *Troubleshooting* manual. The *Troubleshooting* manual contains more detailed information and procedures which require trained and authorized personnel. For this reason the *Troubleshooting* manual is only issued to qualified installers authorized by the Manufacturer.

For more information contact the Manufacturer's CALL CENTER at +49 (0)7461 9472-19.

PROBLEM	CAUSE	REMEDY
The laser does not go on -Display off -Status led off -Fans off	Power absent	Check the power supply wire
		Make sure the fuses are intact
2) The laser does not go on -Display in alarm -Status led off	Interlock enabled with the message "INTERLOCK ENABLED"	Check the external connections (pin 1-2 of the External Interlock connector)
	Interlock enabled with the message "EMERGENCY ENABLED"	Check the external connections (pin 1-2 of the Command Box connector)
	Interlock enabled with the message "START NON OK"	Check the external connections (pin 4-12 of the Command Box connector) Check the opening of the external contact (READY command present before START)
3) The laser does not go on -Display in alarm -Status led off	Voltage protection tripped with presence of Alarm "DC POWER FAULT"	Turn the switch to OFF, wait 10s and turn to ON.
		Contact the Call Centre
4.a) The laser is not enabled -Display in alarm -Status led off	Interlock enabled with the message "ENABLE NON OK"	Check the external connections (pin 7-8 of the Command Box connector)
		Check the opening of the external contact (READY command present before START)
4.b) The laser is not enabled -Display in alarm -Status led green	Power protection tripped with presence of Alarm "MAX POWER ALARM"	Turn the switch to OFF, wait 10s and turn to ON.
		Contact the Call Centre
4.c) The laser is not enabled -Display in alarm -Status led green	Current protection tripped with presence of Alarm "MAX CURRENT ALARM"	Turn the switch to OFF, wait 10s and turn to ON.
		Contact the Call Centre
5) The laser does not go to emission -Display signals STAND-BY -Status led Orange -Laser in STAND-BY	Wait for shutter open command	Check the external connections (pin 7-8 of the Command Box connector)
		Check closing of the external contact (pin 7-8 of the Command Box connector)
6.a) No Laser emission -Display signals READY -Status led Red	Wait for PEN-UP command	Make sure the Personal Computer hardware and software is installed correctly
		Check for the presence of the signal (5V) pin 3 - 2 of the PC connector
		Replace the DSP board in the P.C.
6.b) No Laser emission -Display signals ENABLE -Status led Red	LEVEL signal absent	Make sure the Personal Computer hardware and software is installed correctly

		<p>Check for the presence of the signal (10V) (pin 3 -1 of the PC connector)</p> <p>Replace the DSP board in the P.C.</p>
<p>7) No aiming red laser</p> <p>-Display signals READY</p> <p>-Status led Orange</p>	No power	<p>Check the connection wire between the rack and Resonator</p> <p>Replace the DL connection wire</p>
<p>8.a) The laser stops emitting</p> <p>-Display in alarm</p> <p>-Status led Green</p>	<p>Temperature protection tripped with presence of Alarm</p> <p>“MAX TEMPERATURE ALARM”</p>	<p>Make sure the cooling air circulates freely</p> <p>Make sure the fans are running correctly</p> <p>Check the ambient temperature (max.35 °C)</p> <p>Turn the switch to OFF, wait 10s and turn to ON.</p> <p>Contact the Call Centre</p>
<p>8.b) The laser stops emitting</p> <p>-Display in alarm</p> <p>-Status led Green</p>	<p>Temperature protection tripped with presence of Alarm</p> <p>“M/S HIGH DIODE TEMP”</p>	<p>Make sure the cooling air circulates freely</p> <p>Make sure the fans are running correctly</p> <p>Make sure the radiator is clean</p>
<p>8.c) The laser stops emitting</p> <p>-Display in alarm</p> <p>-Status led Green</p>	<p>Temperature protection tripped with presence of Alarm</p> <p>“M/S INCORRECT DIODE TEMP”</p>	<p>Make sure the cooling air circulates freely</p> <p>Make sure the fans are running correctly</p> <p>Make sure the ambient temperature is above 5 °C and below 35°C</p>
<p>9) Laser emission is irregular</p> <p>-Display signals READY</p> <p>-Status led Red</p>	<p>Variation of the output optical power</p>	<p>Check the output optical power</p> <p>Check the level signal</p>
<p>10) Laser emission is low</p> <p>-Display signals READY</p> <p>-Status led Red</p>	<p>Decrease of the output optical power</p>	<p>Check the hours of operation</p> <p>Contact the Call Centre</p>
<p>11) The scanner head does not work</p>	No power or no signal	<p>Check the connections of the TS and STS wires</p> <p>Replace the DSP board</p>

APPENDIX A:

Technical specifications:

System Specifications

Identification

Laser device model	Megalight™
Product code (O.E.M. set-up)	0EUEM5000
Product code (MARKER set-up)	0EUMA05000 - 0EUMA05001 - 0EUMA05002
Serial number	EUMKxyzzz

N.B.: the device was NOT created and designed to be used in the presence of flammable mixtures.

N.B.: the device was NOT created and designed to be used in category EX environments.

N.B.: the device was NOT created and designed to be used in applications on humans.

N.B.: the device was NOT created and designed to be sold as a finished product.

Conformity

The MEGALIGHT™ device was built in compliance with statutory European Directives related to safety and the constructions provisions for industrial device, specifically it is in conformance with the following European Community Directives:

98/37/EEC	"Machinery Directive"	(for the MARKER version with safety box)
89/336/EEC	"Electromagnetic Compatibility"	(for the O.E.M. version)
73/23 / EEC	"Low voltage"	(for the O.E.M. version)

The main applied standards are listed below:

EN 60204-1	Safety of machinery
EN 60825-1	Safety of laser products
EN 55011-1	Emission standard
EN 61000-6-2	Immunity standard

The device is supplied with the obligatory certification and marks of conformity to the essential safety requirements prescribed by the applied European Directives.

Laser Source Classification

According to Standard CEI EN 60825-1 2001 *Safety of laser devices*.

Working laser source	Class IV pulsed source
Aiming laser source	Class 2M continuous source
Nominal ocular hazard distance (NOHD)	Scattered radiation: 50 cm Direct radiation: 1,500 cm
Goggle minimum Optical Density	>5 @808nm / 1064nm
Light transmittances	>30% 500-700nm

Type of goggles prescribed	DIR
----------------------------	-----

Equipment electrical specifications

Electricity	Single phase 90-240Vac (±10%) 50/60Hz
Rated power	500 VA cosφ = 0.8
Protection fuses	2 x 6.3A / 250V type T (5 x 20 mm)

Environmental and installation specifications

Ambient temperature:	During operation: from +15°C to +35°C Storage: from -5°C to +55°C
Relative ambient humidity	Max 80% without condensation
Altitude:	Max 1500m
Vibration:	Not allowed
Acceleration	Max 0.5R
Protection category	Rack: IP 20 Resonator: IP 54 Engraving Head: IP 54
Type of cooling	Air circulation in filtered environment
Heat charge towards environment	Max WC = 80W
Maximum internal temperature	Dissipaters 60°C
Operating type	Continuous
Acoustic emissions	Max sound level < 65dba

Laser Source Specifications

Working laser	
Enabled medium	Nd:YAG
Wave length	1064nm ± 5nm
Diameter of the beam output by Beam Expander	5mm (@ 1/e ²)
Divergence of the beam output by the Resonator	< 3mrad (full angle)
Mode/Beam quality	TEM00 / M ² <1.2 (@ full power)
Polarization	Random
Operating type	Impulse
Pulse duration	9ns (typical)
Repetition frequency	Fixed 25kHz (typical)
Maximum average power	5W ± 5%
Maximum instantaneous power	28kW ± 20%
Maximum impulse energy	230µJ ± 5%
Point Stability	< 50µrad
Pump Laser Diode	
Wave length	808nm ± 4nm
Rated power	25W ± 10%
Average life	Max 10000 hours
Radiation transmission system	Optical fibre 600µm NA 0.22
Connector type	D80 LKA
Optical fiber minimum curve radius	150mm
Optical fiber standard length	3m
Beam divergence at optical fiber output	400mrad
Aiming Laser Diode	
Wave length	635 nm± 5nm
Maximum power	3mW CW

Mechanical specifications

Dimensions [mm]	Rack:	180x500x450
	Resonator:	70x260x70
	Miniscanner Engraving Head:	110x120x110
Weight (Kg)	Rack:	19
	Resonator:	3
	Miniscanner Engraving Head:	1

O.E.M. device standard equipment

N°	Component	Code	Serial number
1	Rack model DL25	72.5000.1	RK25xyzzz
1	Resonator model MEGALIGHT™	72.5200.1	RISExyzzz
1	Optical fiber 600µm	72.5010	
2	Fuses 6.3A / 250V (5 x 20 mm)	72.5100	
1	Mains power supply wire	50.300	

Separately supplied parts

N°	Component	Code	Serial number
1	Engraving Head Miniscanner model	72.5400.1	E08Yxyzzz
1	Head power supply wire (TS)	72.5500	
1	Head signal wire (STS)	72.5510	
1	PC connection wire	72.5515	
1	Aiming Beam connection wire (DL)	72.5610	
1	F-theta lens 160mm	72.5430.1	
1	DSP2 board for PCI bus		
1	CD-Rom Smartist4		
1	Floppy disk Files .ini		
1	Resonator attachment bracket		
1	Engraving head attachment plate		

MARKER device standard equipment

N°	Component	Code	Serial number
1	Rack model DL25	72.5000.1	RK25xyzzz
1	Resonator model MEGALIGHT™	72.5200.1	RISExyzzz
1	Optical fiber 600µm	72.5010	
2	Fuses 6.3A / 250V (5 x 20 mm)	72.5100	
1	Mains power supply wire	50.300	
1	Engraving Head Miniscanner model	72.5400.1	E08Yxyzzz
1	Head power supply wire (TS)	72.5500	
1	Head signal wire (STS)	72.5510	
1	PC connection wire	72.5515	
1	Aiming Beam connection wire (DL)	72.5610	
1	F-theta lens 160mm	72.5430.1	
1	DSP2 board for PCI bus		
1	CD-Rom Smartist4		
1	Floppy disk Files .ini		
1	Engraving head attachment plate		

Possible field of adjustment

Based on the pump power, the laser emission is a “threshold” process, i.e. the laser action only starts from a certain pump power value and consequently laser diode power supply current value. When the range of the laser diode power supply current is established (maximum value set by the manufacturer), the progress of the power emitted at the Resonator output for the Megalight™ source is shown in the following graph: normally, there is laser action around 45% and 100% of the maximum power supply current value (threshold).

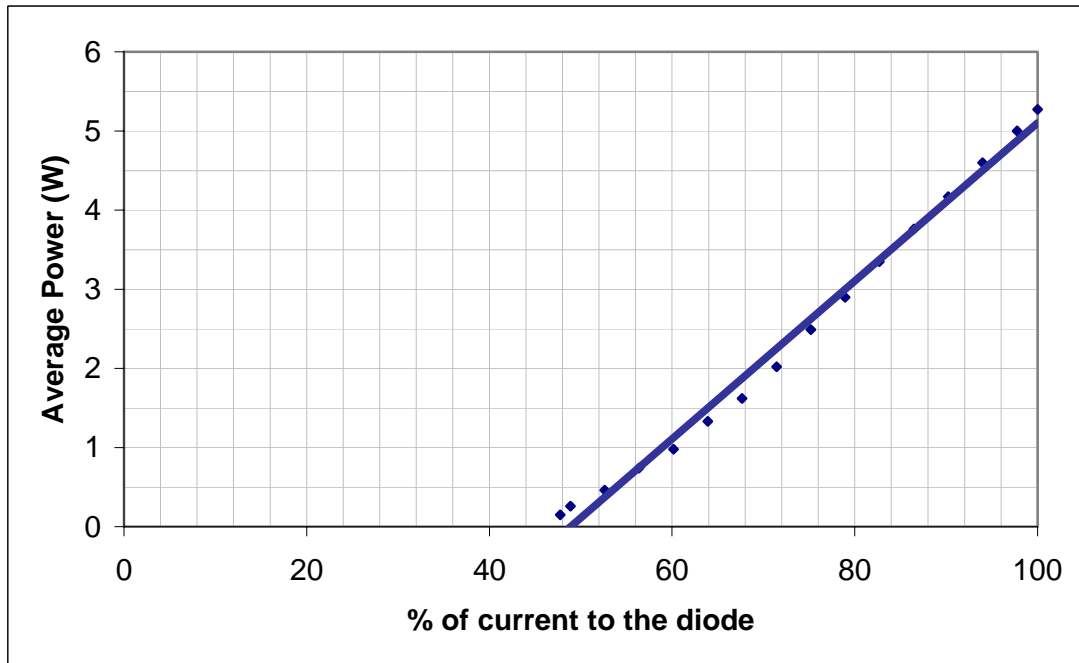

Similarly, the graph below represents the progress of peak power based in the percentage of power supply current:

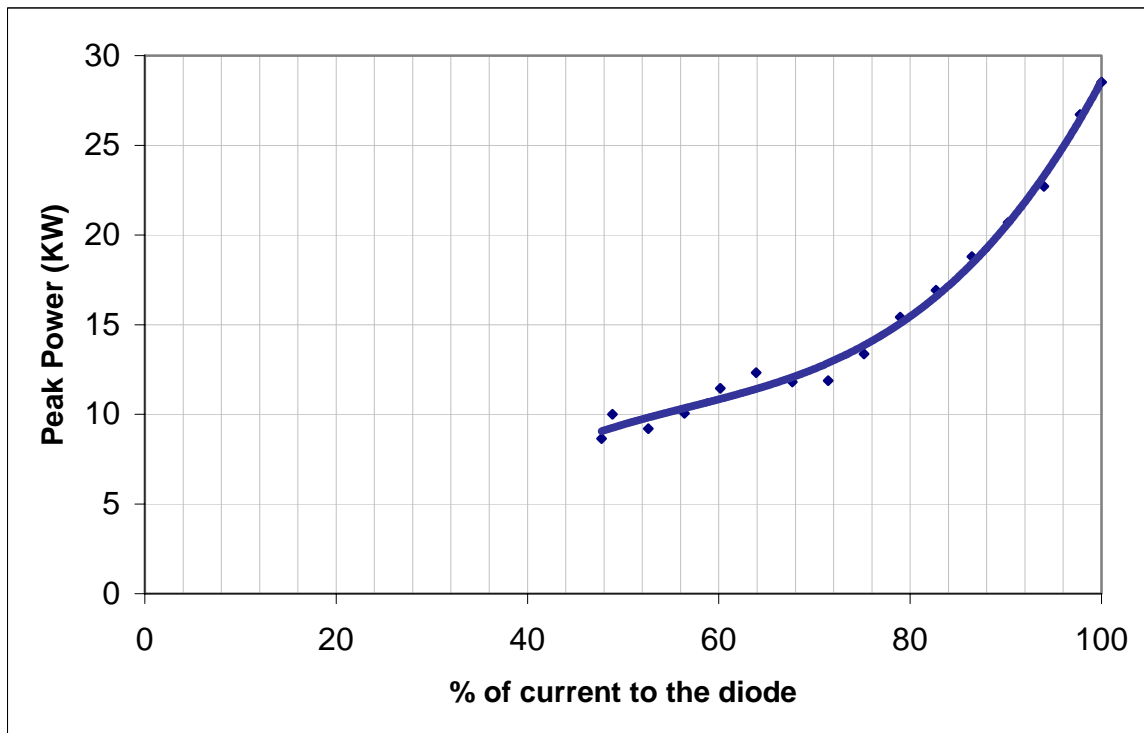

Warning Labels and their positioning

Rack front panel

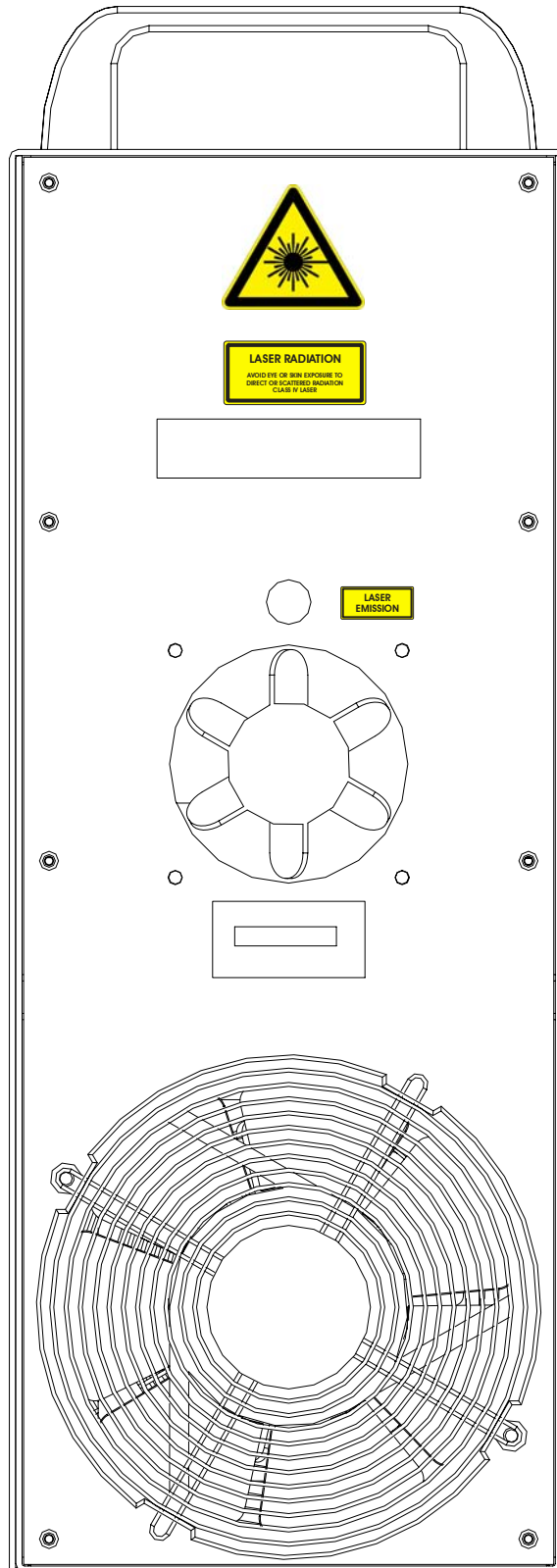

Rack rear panel

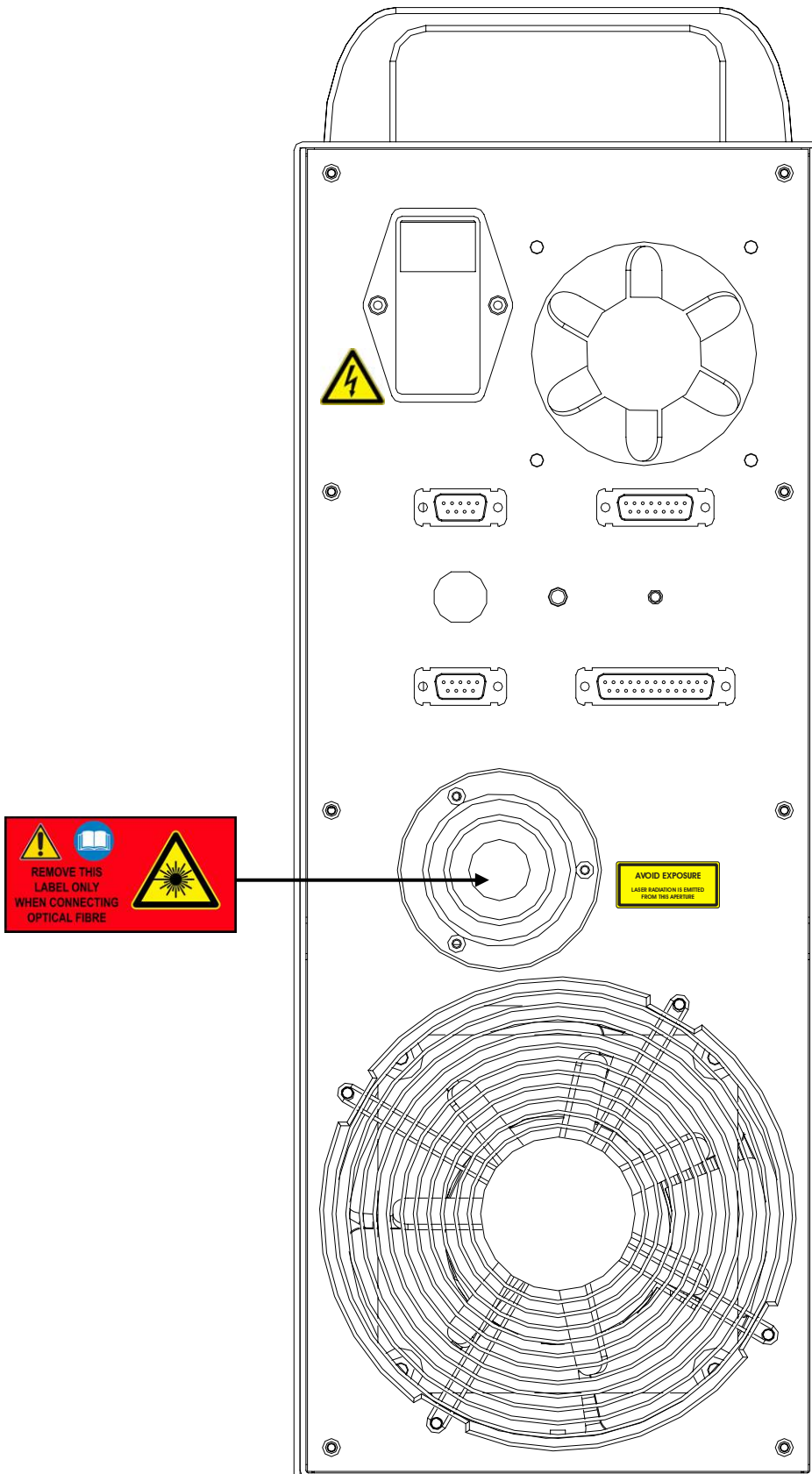

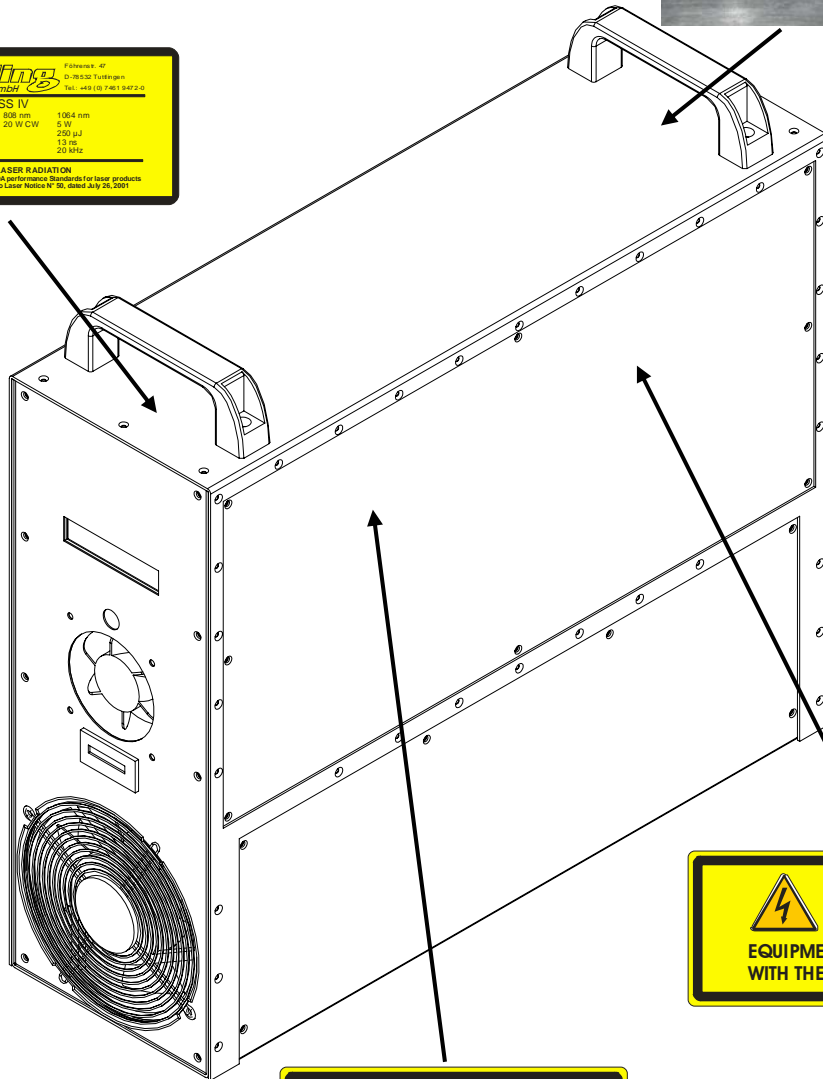
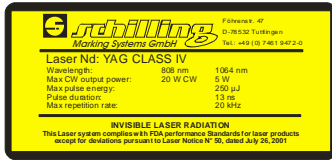



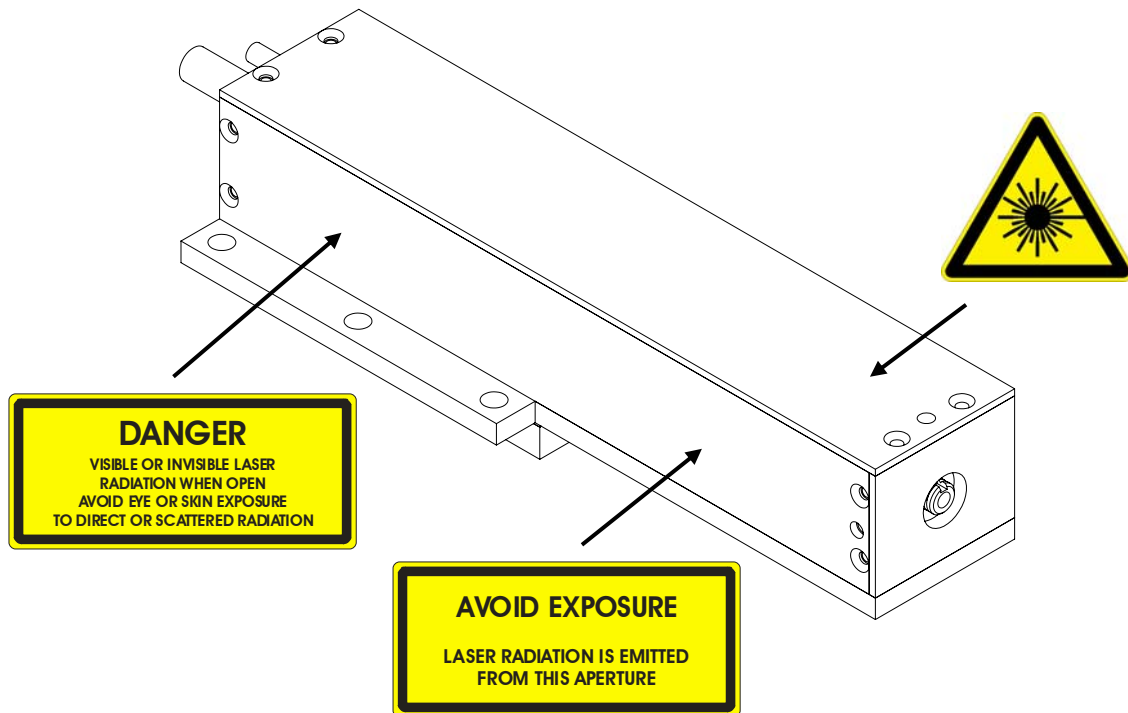

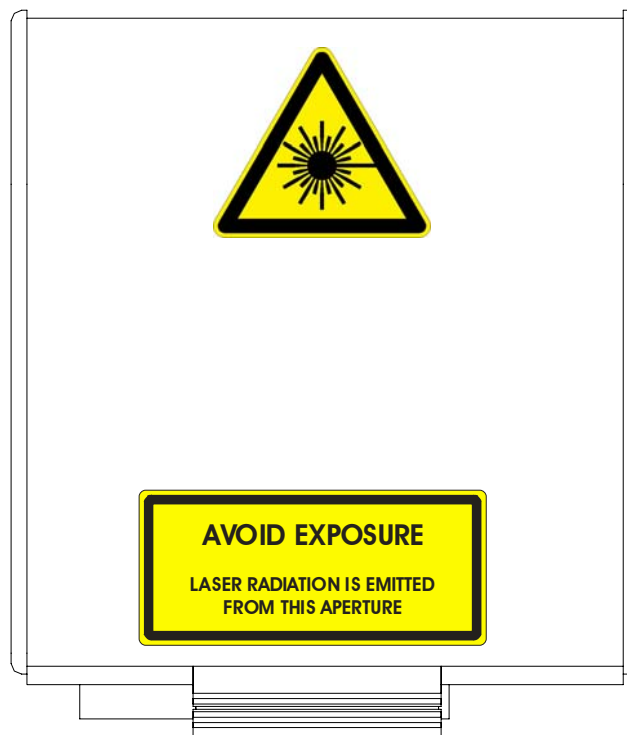

Coupler











Engraving Head



Detailed label description

N°	Label	Type
1		<p>Optical Safety Label</p> <p>Location</p> <p>On the source, panels and covers, in a dominant position so it is visible from all sides and even outside of the optical risk area.</p>
2		<p>Optical Safety Label</p> <p>Location</p> <p>Upper panel of the power supply rack</p>
3		<p>Optical Safety Label</p> <p>Location</p> <p>On every OEM laser device, preferably near label no. 1.</p>
4		<p>Optical Safety Label</p> <p>Location</p> <p>On every Class IV laser device, near the aperture where laser radiation is emitted.</p>
5		<p>Optical Safety Label</p> <p>Location</p> <p>On every guard panel, which once removed allows access to the radiation.</p>

<p>6</p>		<p>Optical Safety Label</p> <p>Location</p> <p>On every moveable panel equipped with a safety interlock.</p>
<p>7</p>		<p>Optical Safety Label</p> <p>Location</p> <p>On the mobile part of a casing containing a visible aiming laser which is not turned off in the event of opening, if the class of the aiming beam is $\leq 2M$.</p>
<p>8</p>		<p>Optical Warning Label</p> <p>Location</p> <p>Front power supply rack panel: it indicates laser emission when the led is red.</p>
<p>9</p>		<p>Electrical Safety Label</p> <p>Location</p> <p>Near the electrical sockets.</p>
<p>10</p>		<p>Electrical Safety Label</p> <p>Location</p> <p>On every guard panel (irremovable), which once removed allows access to the radiation.</p>

<p>11</p>		<p>General Warning Label</p> <p>Location</p> <p>On the OPTICAL FIBER connector of the power supply rack, when the optical fiber is disconnected.</p>
<p>12</p>		<p>Component identification plate</p> <p>Location</p> <p>On every removable Laser component.</p>
<p>13</p>		<p>Device identification plate</p> <p>Location</p> <p>Upper panel of the power supply rack</p>

Mechanical drawings

The following drawings show:

- Overall mechanical view of the Resonator and Engraving Head (OEM set-up)

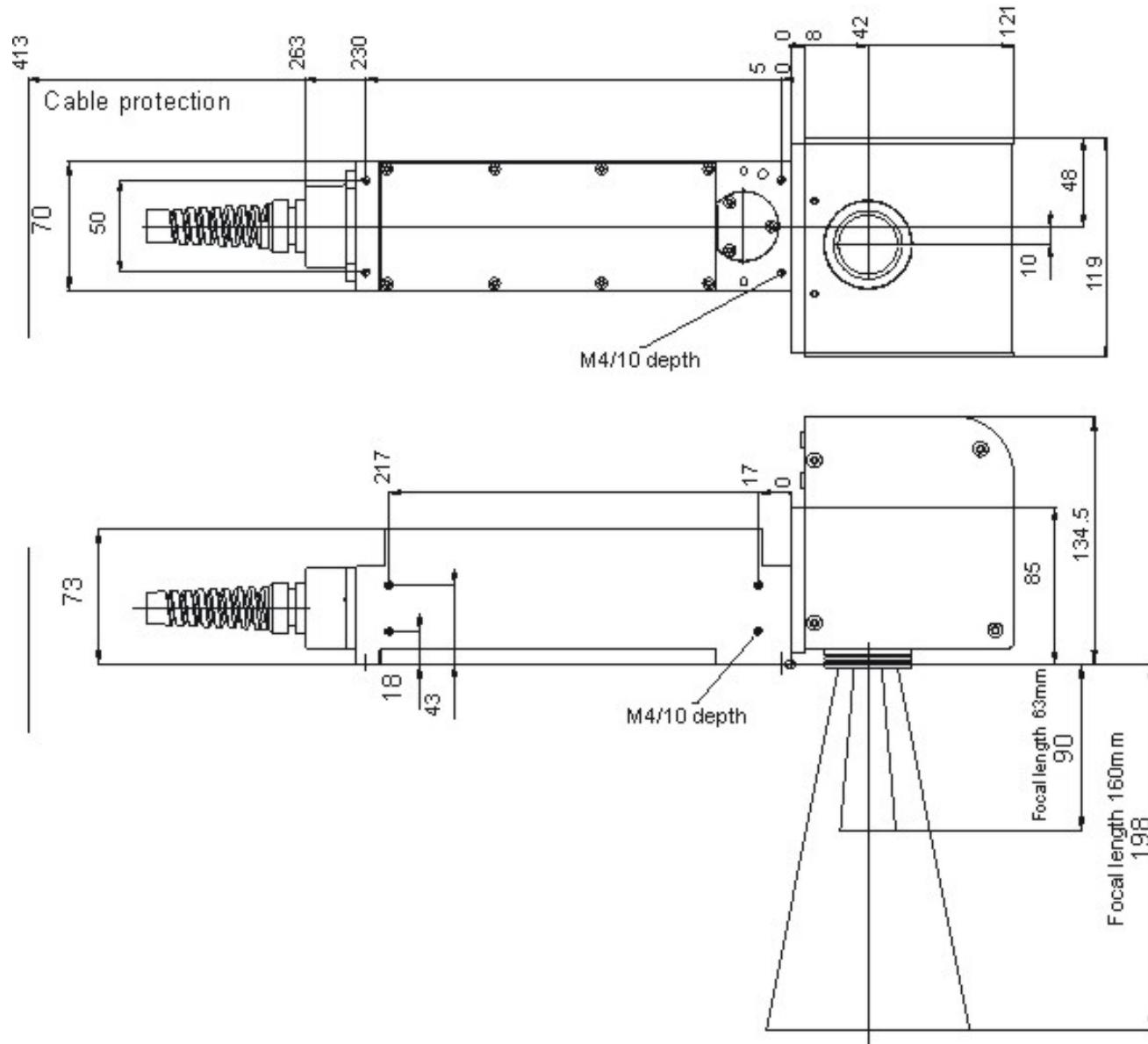

APPENDIX B:

Wiring diagrams

Description of signals on connectors

Command Box (CB) Connector

On this connection all the inputs / outputs indispensable for control and interface of the device with the external devices necessary for creating an engraving system.

The figure below shows the contact sequence of the 25 pin female connector located on the rear panel of the power supply box:

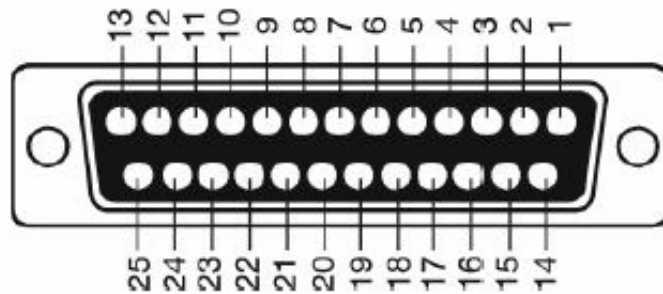

Picture 13: Command Box Connector (25p / f)

Input

Pin N°	Signal	Description	Status
1 (+)	Potential free contact	STOP LASER	Contact open = STOP
2 (return)	Potential free contact		
4 (+)	Potential free contact	START	Contact closed = START
12 (return)	Potential free contact		
7 (+)	Potential free contact	STAND BY / READY	Contact open = STAND BY Contact closed = READY
8 (return)	Potential free contact		

Output

Pin N°	Signal	Description	Status
18	H/L logic	POWER ON	0 Volt = Laser power off 12 Volt = Laser power on
19	0V	GND	GND reference for pin 18
20	H/L logic	LASER READY	0 Volt = Laser ready 12 Volt = Laser not ready
21	0V	GND	GND reference for pin 20 and 22
22	H/L logic	LASER ENABLE	0 Volt = Laser Disabled 12 Volt = Laser Enabled

Warning: Pins **3-5-6-9-10-11-13-14-15-16-17-23-24-25** not assigned in the list are internally connected and used by the Manufacturer. **Do not use any connection of those indicated in the table above!**

N.B.: The time sequence of the commands is described in the *Timing Diagram* paragraph.

External Interlock Connector

It is possible to connect all the emergency devices aimed at making the laser source safe, in series with this connector.

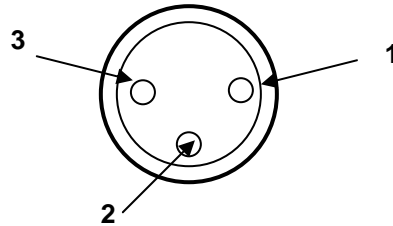

Picture 14: External Interlock connector (3p / f)

Pin N°	Signal	Description	Status
1 (+)	Potential free contact	INTERLOCK	Open contact = Emergency Enabled
2 (return)	Potential free contact		
3	0 V	GND	

N.B.: If the emergency is enabled by opening the Interlock contact it cannot be reset. Resetting is only possible by putting the main switch MS in the Open position (**O**) and then the closed positions (**I**).

Galvo Supply Connector

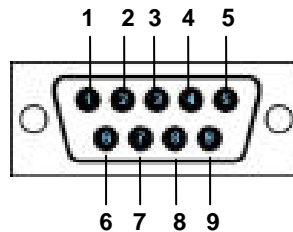

Picture 15: Galvo Supply Connector (9 p /m)

Pin N°	Signal	Description	Status
1-6-2 (-)	- 15 V	NEGATIVE SUPPLY	Negative power supply -15V / 3° max
7-3-8 (0)	0 V	COMMON	Common
4-9-5 (+)	+15 V	POSITIVE SUPPLY	Positive power supply +15V / 3° max

Slave Out Connector

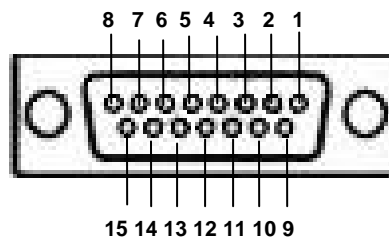

Picture 16: Slave Out Connector (15p / f)

Pin N°	Signal	Description	Status
1 (+)	+12 V	-----	Not used in this version
9 (+)	+24 V	-----	Not used in this version
15 (0)	0 V	-----	Not used in this version
2-3-4-5-6- 7-8-10-11- 12-13-14	n.c.	-----	Internal connections (do not use)

P.C Connector

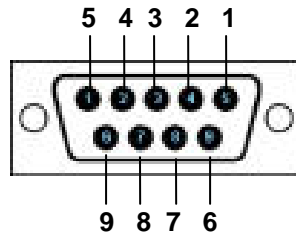

Picture 17: PC Connector (9 p / f)

Pin N°	Signal	Description	Action
1 (+)	Analogy 0-10V	POWER LEVEL	Regulates Laser power
6	-----	-----	Not used in this version
2 (+)	H/L logic	PEN UP	Up = Engraving impulse emission
8	+12 V	EXTERNAL SUPPLY	External Positive Power Supply +12V / 50mA min.
3	0 V	COMMON	0V External power supply / Signal common

Aiming Beam Connector

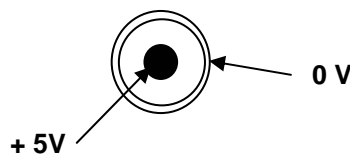

Pin N°	Signal	Description	Status
+5V	Logic 3.5 - 5 V	POSITIVE	Aiming Laser Positive Power Supply
0V	0 V	RETURN	Aiming Laser Power Supply 0V

R.F. Connector

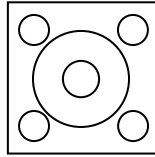

Pin N°	Signal	Description	Status
-----	-----	-----	Not used in this version
-----	-----	-----	Not used in this version

Wiring diagrams

The Manufacturer agrees to supply upon request the circuit diagrams, lists of component parts, calibration instructions or other information useful for adequately qualified personnel to repair the parts of the device which the Manufacturer considers repairable.

The following diagrams are supplied:

- Rack interface wiring diagram.
- Interface signal timing diagram.
- Laser command signal timing diagram.
- Wiring diagram of DSP2 (optional) command signals.
- Interface wiring diagram for the DSP2 (optional) board I/O module.

DWG n° **E203AL004**

DESCRIPTION

VIOLINO EUMARKER EXTERNAL WIRING

REVISED

REL. 03

External back-up fuses 16A gG / gL

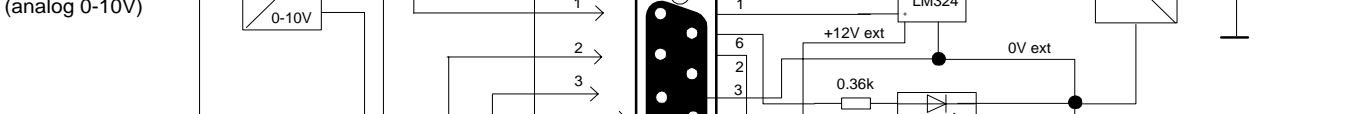
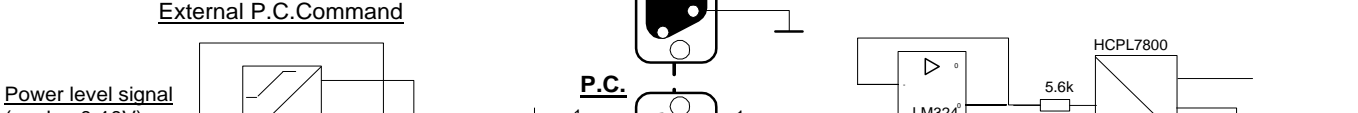
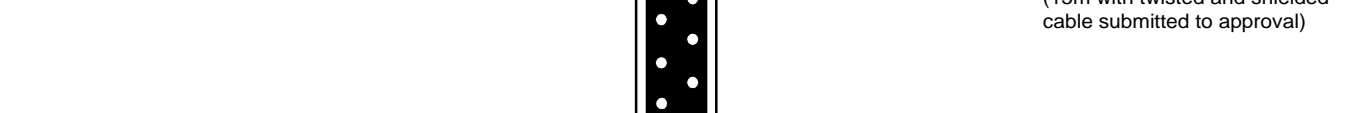
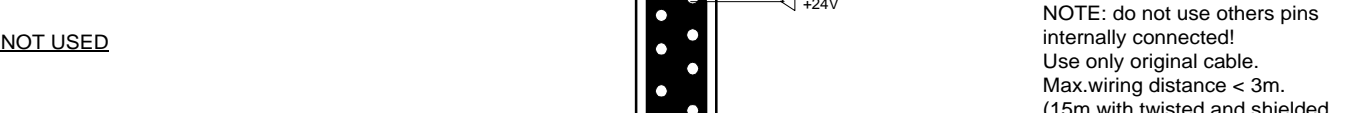
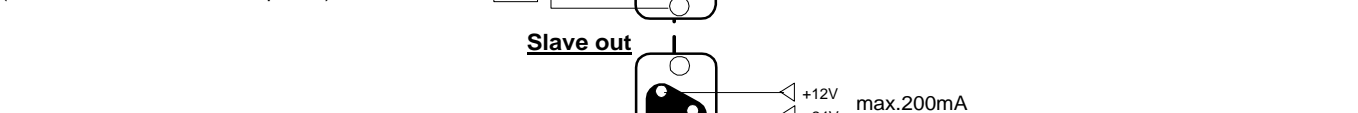
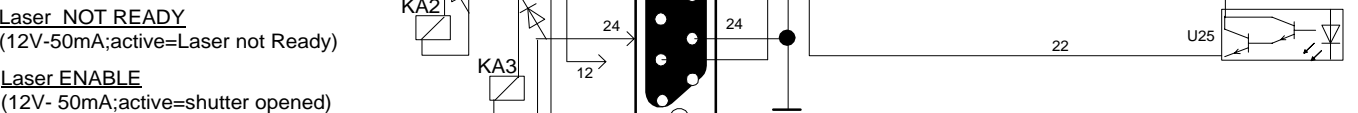
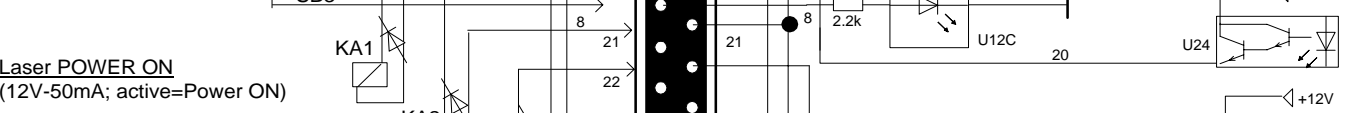
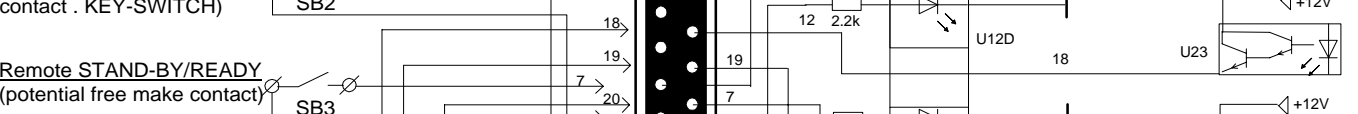
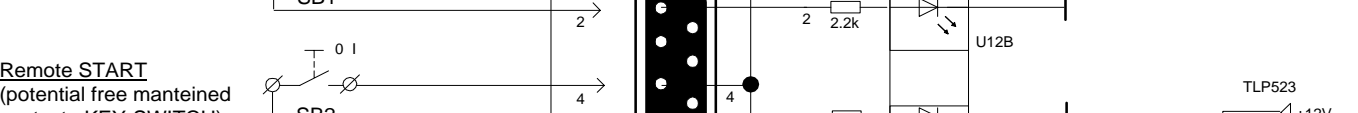
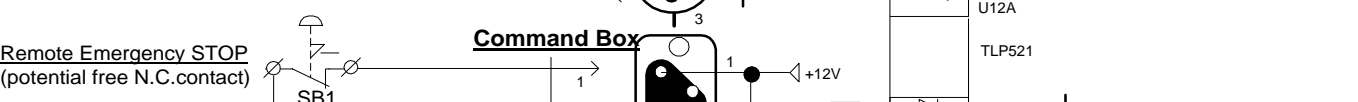
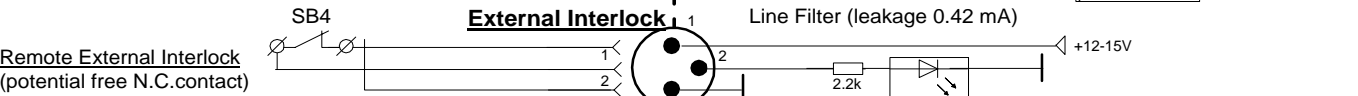
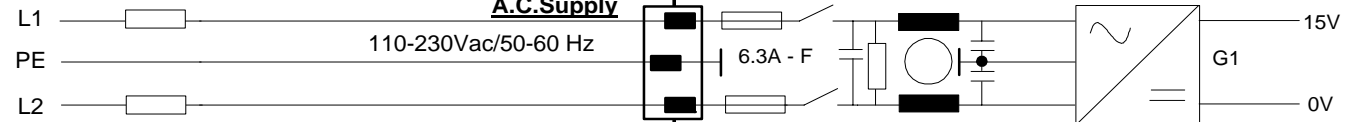

NOTE: do not use others pins internally connected!
Use only original cable.
Max.wiring distance < 3m.
(15m with twisted and shielded cable submitted to approval)

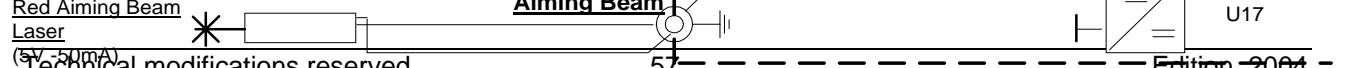
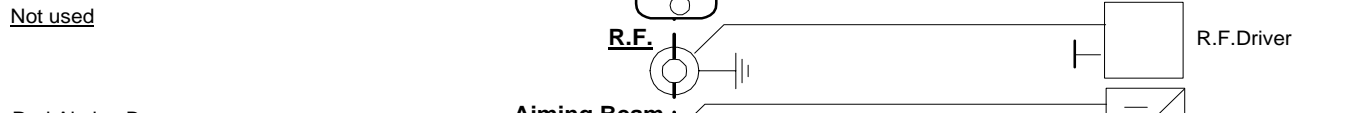
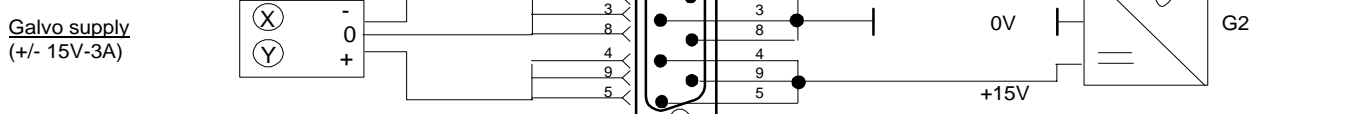
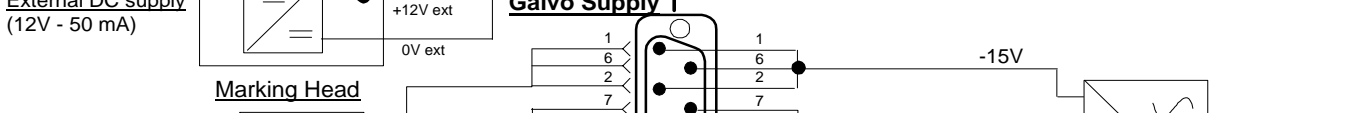
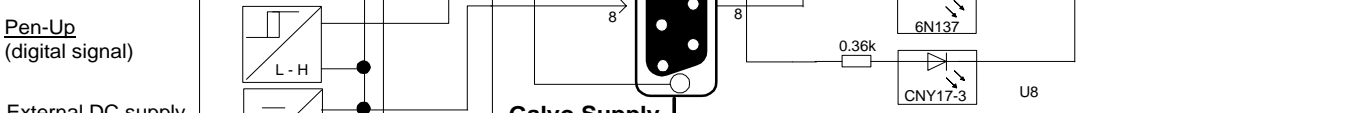

Technical modifications reserved 57 Edition 2004

Remote EmergencySTOP
(Connector Command Box
Pin 1-2)

Remote External Interlock
(Connector Ext.Interlock
Pin 1-2)

Remote START
(Connector Command Box
Pin 4-12)

Laser POWER ON
(Connector Command Box
Pin 18-19)

Laser NOT Ready
(Connector Command Box
Pin 20-21)

Remote STAND-BY/READY
(Connector Command Box
Pin 7-8)

Alarm or Warning
(internally generated)

Laser ENABLE(Beam Attenuation off)
(Connector Command Box
Pin 22-24)

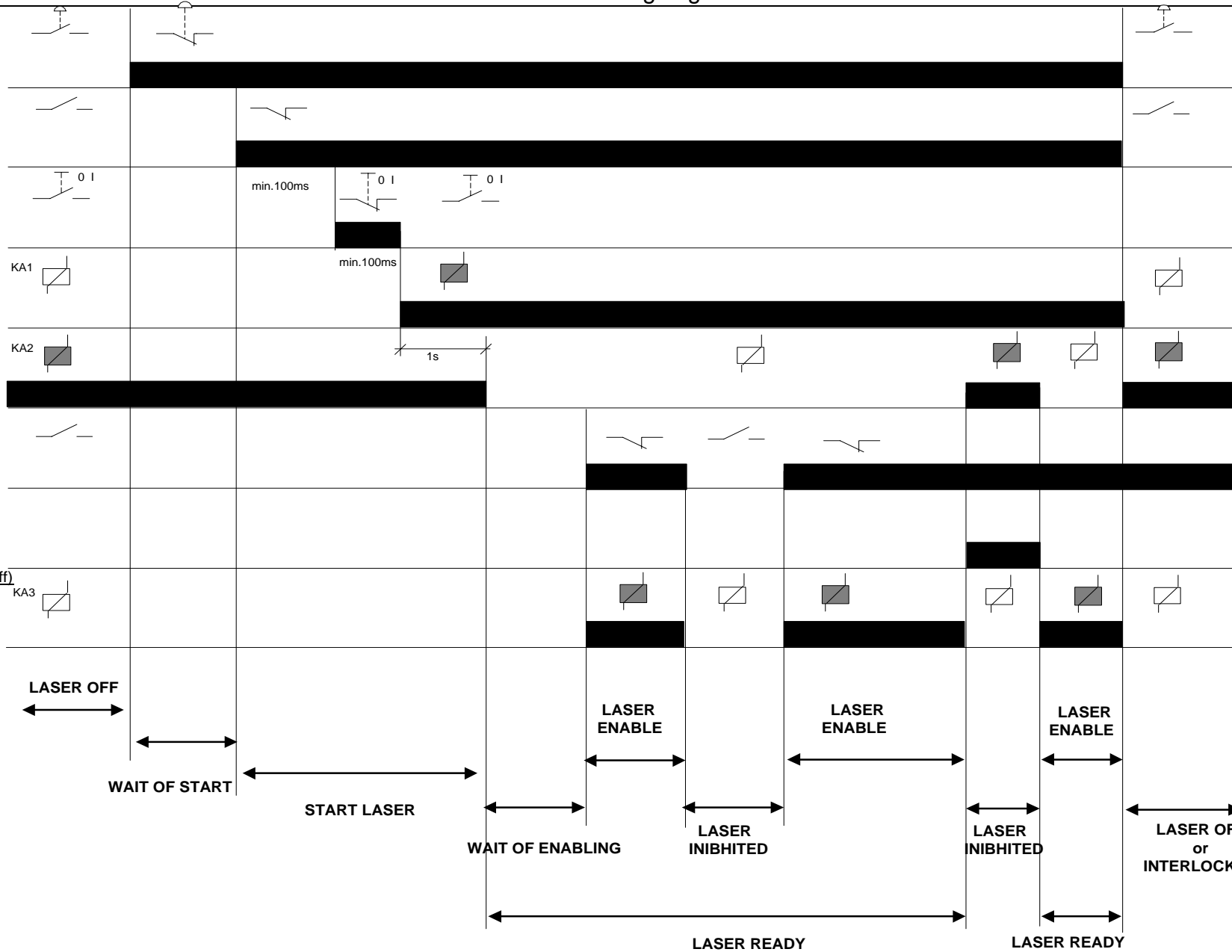

NOTE:

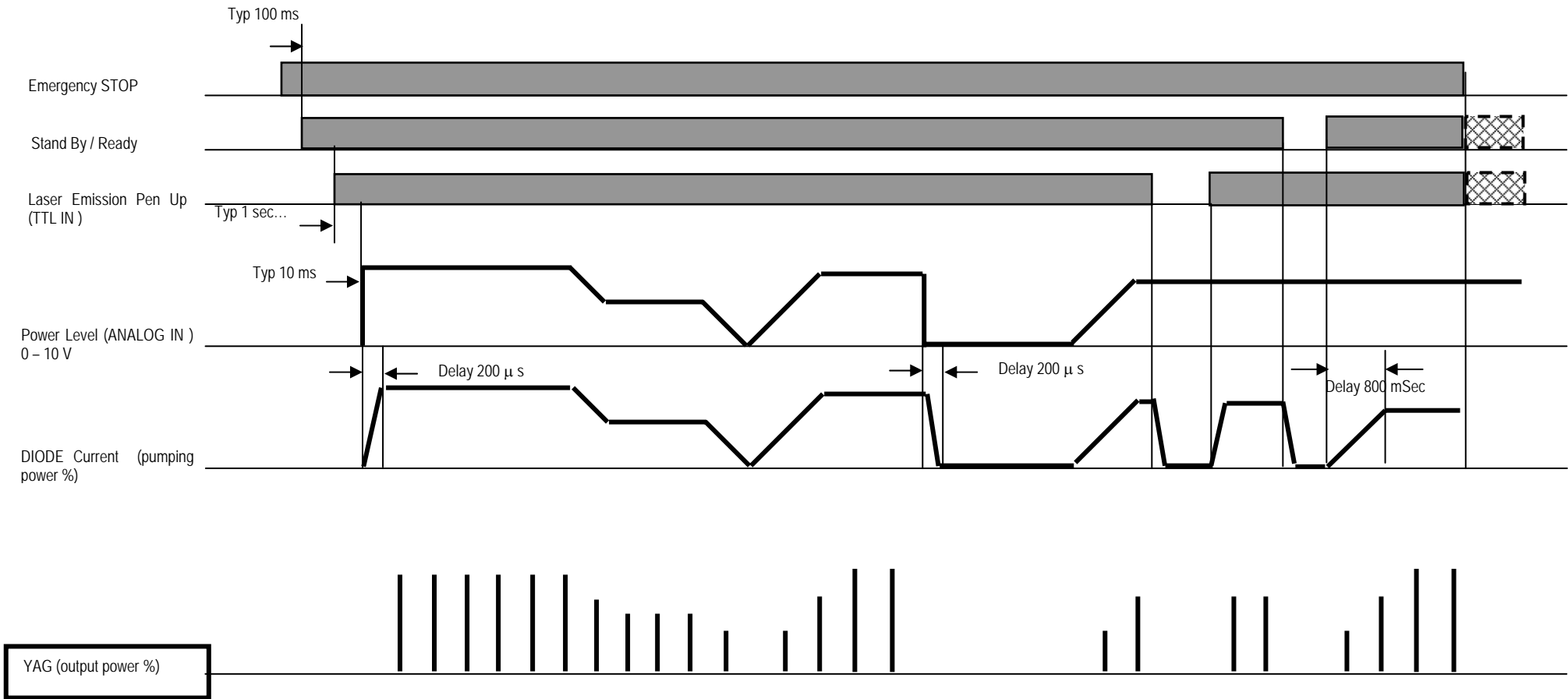

to Scanner Head Digital /Analogic Converter

to RACK VIOLINO -P.C.Connector

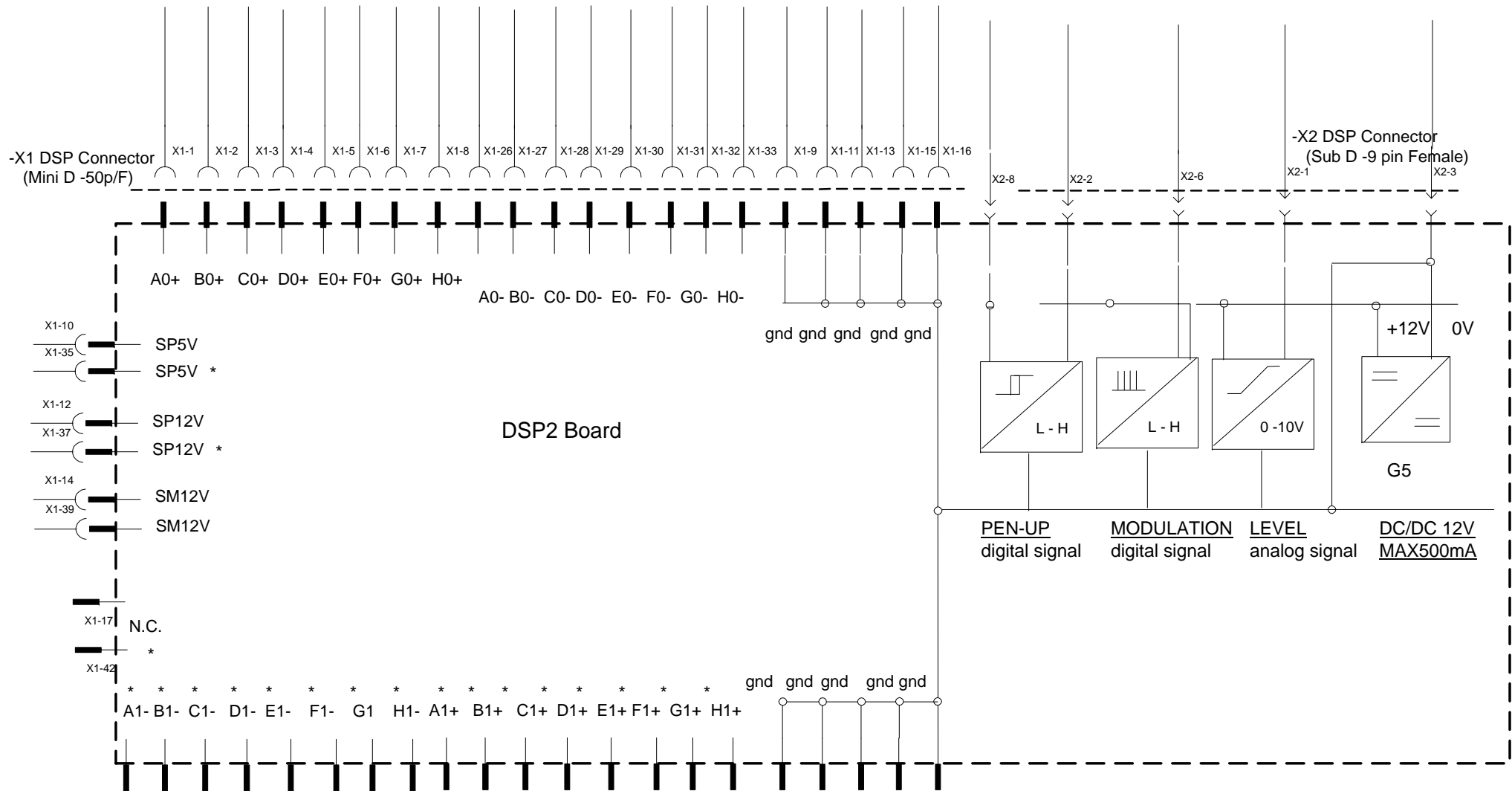

* not used

DWG n° E203AL004

MODULE 0 EXTERNAL WIRING

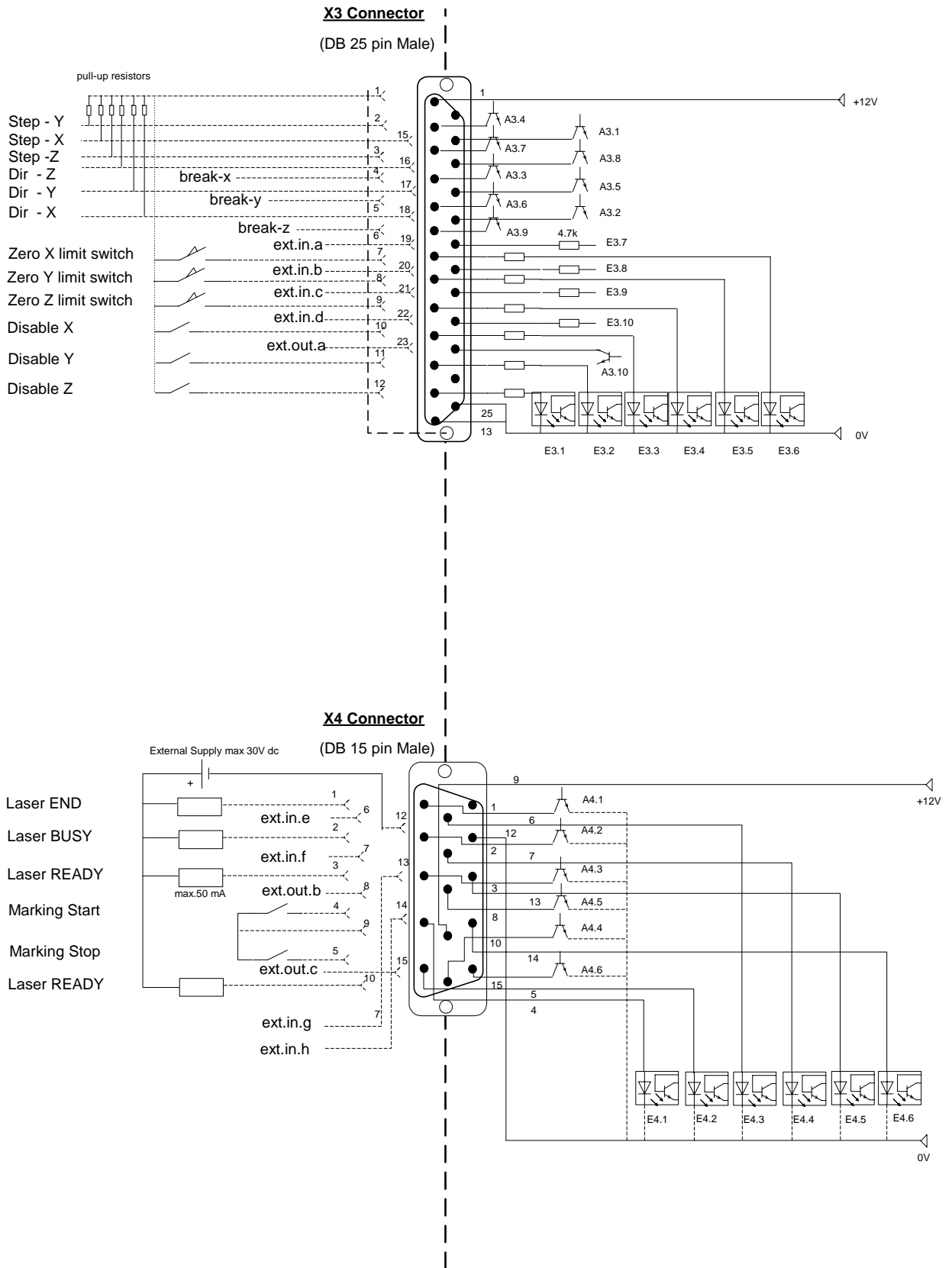

APPENDIX C:

Safety notes

Auto diagnosis chart for the installer related to the completeness of safety measures on a Class I laser device containing Class IV laser sources.

In conformity with the provisions of the following standards:

EN61040
 EN60825-1
 EN 207
 EN 208
 EN 12626
 CEI 60825-5

REQUESTED REQUIREMENT	SOLUTION TO ADOPT	PROOF	YES	NO	NA
1) The Classification of the finished laser system must be class I	If the class of the source is greater than I, the level of accessible radiation must be brought to the limits of class I	Presence of suitable protection barriers. N.B.: goggles are considered as an additional but not alternative measure!			
2) The laser radiation must be completely confined and end at the end of its optical path	Closing of the optical path up to the point of application and confinement of the reflected and scattered radiation in a specific opaque container applied to the radiation.	No crack or opening must make the radiation accessible for viewing. N.B.: If the optical fibre is greatly bent it does not comply with this provision! However it should not be disconnect able without using a tool.			
3) The observation windows must have an optical density and stability to the radiation able to resist the maximum forecast radiation, even in the event of a first fault, to which they may be subject. The windows must be of a type and construction sufficiently robust to withstand the maximum forecast mechanical stress.	Adopt filters suitable for the wavelength, use procedure, scale index, adapted to the laser and maximum power which can be used. The filters must be permanently attached to the protection casing.	Certification from the manufacturer on the suitability of the filter. Calculations on the necessary O.D. in the worst condition which can occur. Attachment with mechanical systems which require a tool for removal.			

<p>4) The fixed covering panels must not be able to be removed without the use of a tool, after they have been removed they must not be able to remain in position without being attached.</p>	<p>Screw down the cover panels with screws avoiding frames and bends which can hold the panels in place even without screws.</p>	<p>Mechanical construction suitable for ensuring that they do not move without the use of specific tools.</p>			
<p>5) Movable panels and/or doors must be interlocking with the laser radiation so that their opening reduces the accessible radiation to the levels of class I. Restoration of the laser radiation must only take place after a subsequent intentional manoeuvre and not following simple reclosing of the door.</p>	<p>Fit the doors and removable panels with limit switches to connect to the remote locking connector of the laser. If a mechanical hazard exists as well, the limit switches must also interlock any movements in process.</p>	<p>Presence and functionality of the limit switch with forced opening and positive manoeuvre.</p>			
<p>6) The laser system must be started only with a manual command via an intentional manoeuvre effected by trained personnel with a key device.</p>	<p>Fit a key device which can be removed in the off position.</p>	<p>No possibility of starting without the key and activating it. Removable key in the off position. N.B.: a reset modification to the standard permits considering a software password or badge as a key.</p>			
<p>7) An acoustic or luminous warning must signal the imminent presence and then presence of laser radiation.</p>	<p>Fit a light that goes on when the laser is enabled and thus ready to emit its radiation upon a command.</p>	<p>The light must go on at least 5 seconds before the laser is emitted and with the light off (laser in stand-by) any emission commands must not activate radiation in any way.</p>			
<p>8) A manual beam attenuation command must be available at all times.</p>	<p>Install a button which acts on the electromechanical or electronic shutter</p>	<p>The action of the shutter must immediately stop or attenuate the radiation to levels under those allowed for class I. A subsequent release action may allow the radiation to be restored</p>			
<p>9) A remote lock connector must be available and connected to the interlock devices.</p>	<p>Use a specific connector to install a connection to the remote external lock limit switches (see point 5).</p>	<p>Opening of this circuit must lead to a reduction of the accessible radiation to the levels of class I. Restoration of the laser radiation must only occur after a subsequent intentional manoeuvre and not by simply reclosing the circuit.</p>			

<p>10) A manual laser emergency command must be available, separate from the line switch.</p>	<p>Install a red mushroom head button with appropriate laser emergency labeling (CEI symbol) with priority over all other commands.</p>	<p>Activation of the mushroom head button with forced opening contacts must stop the radiation immediately which must not be able to reactivate unless the restart procedure is carried out. N.B.: if the laser device is installed in a more complex system, e.g. a robot or engraving line, which also have a mushroom head button, two emergency circuits with different functions are not allowed! Therefore it is necessary to create a single emergency circuit which stops both the machine and laser, the second mushroom head on the laser will identify the secondary circuit which only acts as a laser emergency.</p>			
<p>11) All the warning labels required for Class IV must be present on the source.</p>	<p>Install warning labels no. 1-no. 2-no. 3-no. 4 See "Warning labels".</p>	<p>The labels are positioned and have the form, dimensions and description corresponding to the Standard provisions.</p>			
<p>12) All the warning labels required for class I must be present on the system.</p>	<p>Install the "Laser class I" warning labels.</p>	<p>No other label is necessary if label no. 1 is usually put on.</p>			
<p>13) A warning label needs to be present on the interlocking panels, doors</p>	<p>Install warning label no. 6 See "Warning labels".</p>	<p>The labels are positioned and have the form, dimensions and description corresponding to the Standard provisions.</p>			
<p>14) Parts containing dangerous voltage must have appropriate warning plates regarding electrical risks.</p>	<p>Install warning labels no. 9-No. 10 See "Warning labels".</p>	<p>The labels are positioned and have the form, dimensions and description corresponding to the Standard provisions.</p>			
<p>15) The electrical cabinet must have a plate identifying the device.</p>	<p>Install warning label no. 13 See "Warning labels".</p>	<p>The labels are positioned and have the form, dimensions and description corresponding to the Standard provisions.</p>			

Note 1: If the provision is not applicable (NA) objective data must support its actual non-applicability.

Note 2: The labels must be in the Manufacturer's language, if the product is not intended for export, otherwise, if intended for export, EVEN TEMPORARILY, it must be in the country of destination in the European Community.

Note 3: For export to the United States the following warning needs to be applied:

NOTICE

This laser component complies with FDA Performance Standards for Laser Products except for deviations pursuant to Laser Notice N°50, dated July 26, 2001.

since there is a difference not yet transposed by Federal regulations 21 CFR 1040 between the provisions of standard CEI 60825 and the provisions of these Federal regulations.

